

Precise controllability for  
severe, high energy or  
continuous slip applications

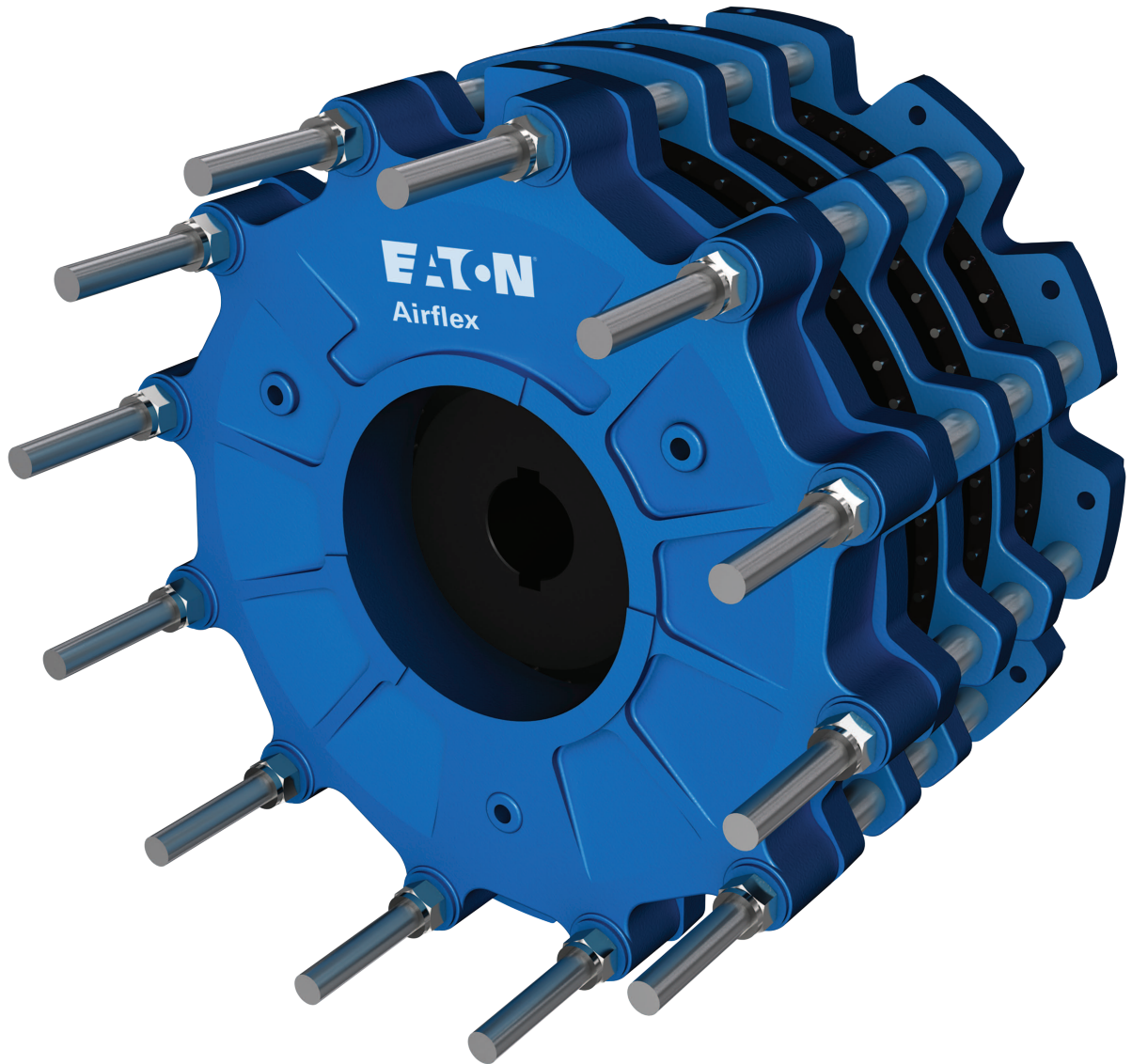

*Powering Business Worldwide*

# Airflex® Water Cooled Brakes WCB2 and WCBD

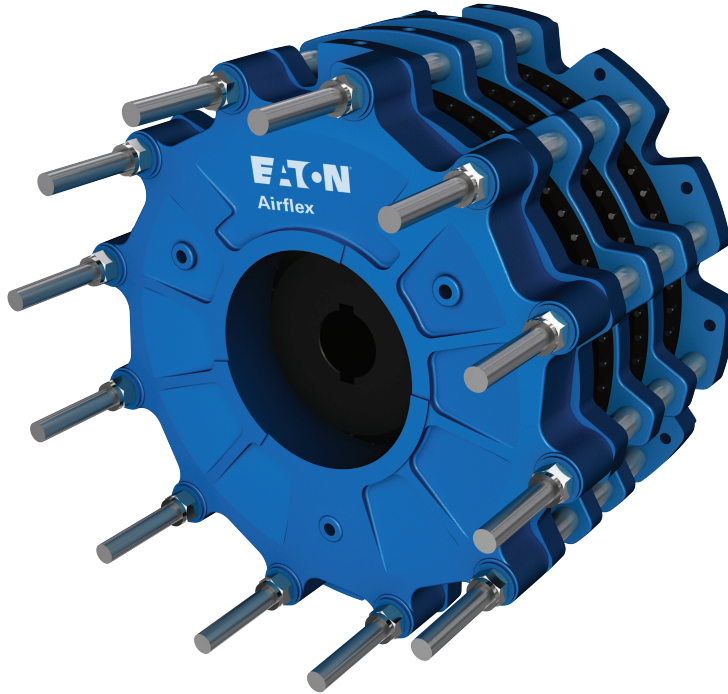

## WHERE USED

- Drilling rigs
- Dynamometers
- Logging equipment
- Marine mooring systems
- Slip clutches
- Tension brakes
- Unwind stands

WCB elements are disc type, externally cooled units. They are designed to absorb and dissipate the thermal loads associated with the most severe clutch and brake applications. The WCB friction couple was developed specifically for continuous slip service and has a dynamic coefficient of friction that is greater than its static coefficient of friction. Also available, special high coefficient linings, which provide 50% higher torque than standard friction linings and provide a 1:1 dynamic to static torque ratio.

Element construction and operation is illustrated in the figure on page 3. Pressurizing the cylinder causes the piston to clamp the friction disc between the water jackets. Heat generated at the friction interface is quickly transferred to the circulating coolant.

Element sizes are indicated by the number of friction discs and the disc diameter in inches. For instance, size 224WCB has two (2) friction discs 24 inches in diameter.

## Features:

### Patented piston design

Single or dual piston provides wider range of applied tension with greater control.

### Drop in powerhead package

Standard single piston elements can be retrofitted with a dual piston powerhead to provide increased control.

### Split wear spacers

The split wear spacers allow for wear adjustment without disassembly of the brake to minimize downtime and maintenance costs.

### Unique friction couple

A specially formulated friction material, interfacing with a copper alloy surface, eliminates the stick-slip characteristic associated with ordinary frictional devices.

### Rapid heat dissipation

The copper interface conducts heat rapidly to the circulating coolant.

### Open or closed loop coolant systems

The element works equally well with open or closed loop circulating systems. On mobile equipment, the engine's cooling system can be tapped to provide coolant to the element.

### Optional corrosion protection

For marine environment applications, protective coatings are available to minimize corrosion.

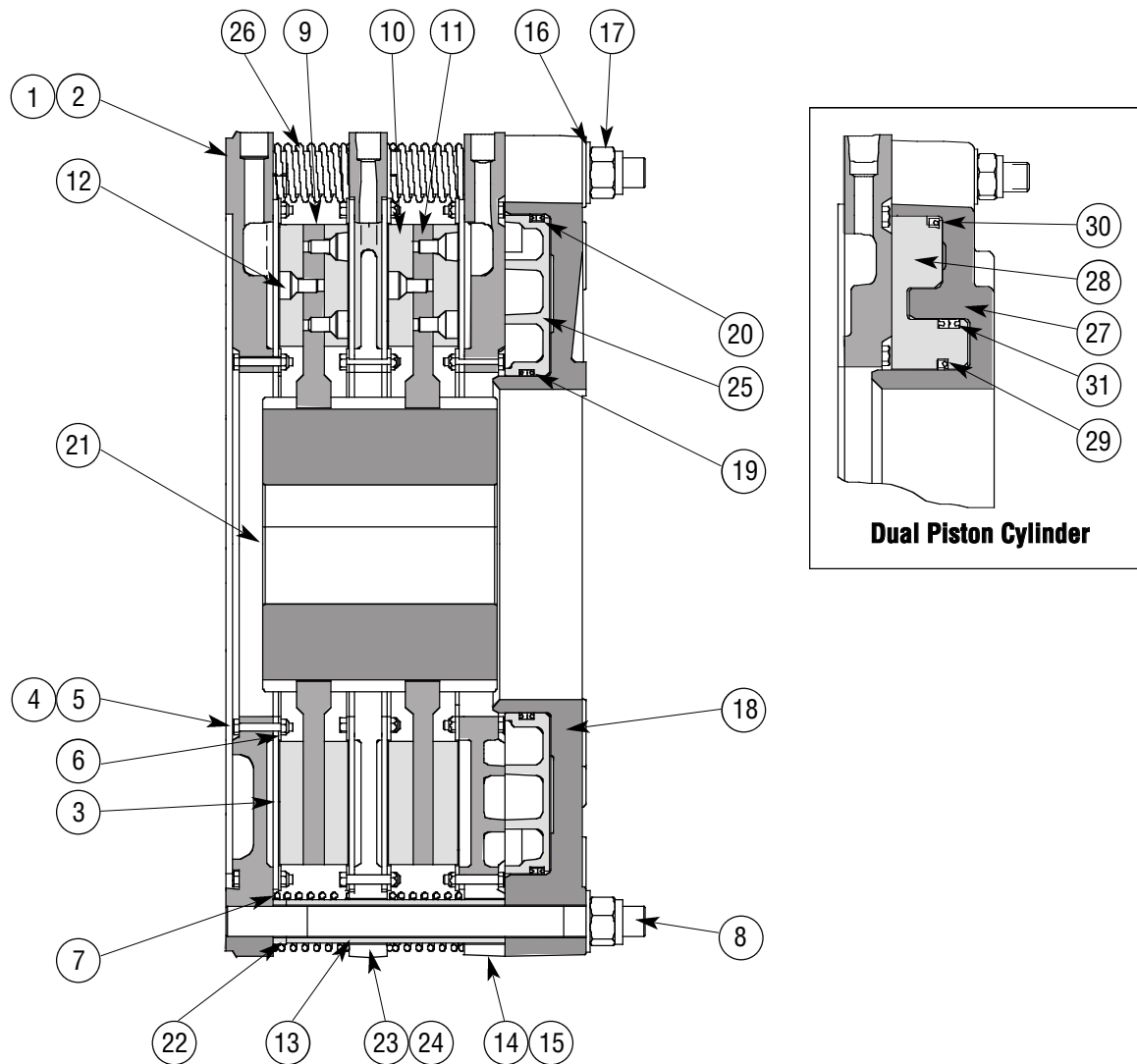

## WCB2 & WCBD Component Parts

Item	Description
1	Mounting Flange Sub-Assembly
2	Mounting Flange
3	Wear Plate
4	Hex Head Screw
5	Locknut
6	Inner Support Ring
7	Outer Support Ring
8	Stud
9	Friction Disc Sub-Assembly
10	Friction Disc
11	Friction Disc Core
12	Flat Head Screw
13	Clamp Tube
14	Pressure Plate Sub-Assembly
15	Pressure Plate
16	Flat Washer

Item	Description
17	Lock Nut
18	Cylinder
19	Inner Seal
20	Outer Seal
21	Gear
22	Wear Spacer
23	Reaction Plate Sub-Assembly
24	Reaction Plate
25	Piston
26	Release Spring
27	Dual Piston Cylinder
28	Dual Piston
29	Dual Piston Inner Seal
30	Dual Piston Outer Seal
31	Dual Piston Intermediate Seal

### Note:

Dual disc unit shown. Other multi-disc units are similar. Items 23 and 24 are not required for single disc units.

# WCB2 & WCB3 Elements: Dimensional Data\*

## Mounting Bolt Circles <sup>⊙</sup>

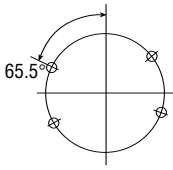

Coolant Inlet Port  
**8WCB**  
(4) 0.531 (13,5)Ø Dia.  
Mounting holes  
based on 6 equally  
spaced as shown  
on 11.125 (282,5)  
bolt circle

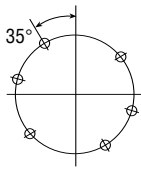

Coolant Inlet Port  
**14WCB**  
(6) 0.656 (16,7)Ø  
Dia. Mounting holes  
based on 8 equally  
spaced as shown  
on 17.500 (444,5)  
bolt circle

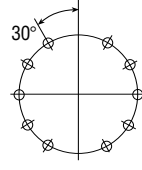

Coolant Inlet Port  
**18WCB**  
(10) 0.656 (16,75)Ø  
Dia. Mounting holes  
based on 12 equally  
spaced as shown  
on 22.000 (558,8)  
bolt circle

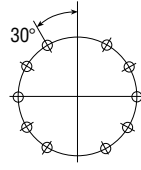

Coolant Inlet Port  
**24WCB**  
(10) 0.656 (16,75)Ø  
Dia. Mounting holes  
based on 12 equally  
spaced as shown  
on 28.750(730,3)  
bolt circle

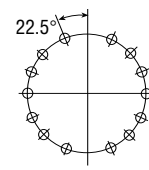

Coolant Inlet Port  
**36WCB**  
(14) 1.062 (27,0)Ø  
Dia. Mounting holes  
based on 16 equally  
spaced as shown  
on 42.000 (1066,8)  
bolt circle

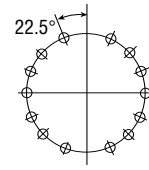

Coolant Inlet Port  
**48WCB**  
(14) 1.438 (36,5)Ø  
Dia. Mounting holes  
based on 16 equally  
spaced as shown  
on 54.000 (1371,6)  
bolt circle

### English Dimensions in inches

Size	D <sub>24</sub>	D <sub>25</sub>	D <sub>29</sub>	D <sub>46</sub>	D <sub>43</sub>	G <sup>⊙</sup>	No. H <sub>3</sub> <sup>⊙</sup>	Size H <sub>3</sub> <sup>⊙</sup>	Bolt Circle H <sub>3</sub> <sup>⊙</sup>	H <sub>10</sub>	H <sub>13</sub> <sup>⊙</sup>	J <sub>1</sub>	J <sub>2</sub> <sup>⊙</sup>
8WCB	0.81	1.25	0.250	⊙	2.62	12.125	8	1/2-13	10.875	4.12	8.375	3.12	12.24
14WCB	0.91	1.41	0.250	⊙	2.90	18.750	8	3/4-10	17.000	7.12	14.375	6.00	18.94
18WCB	0.93	1.47	0.250	1.25	3.14	23.25	12	3/4-10	21.750	11.00	18.250	8.50	23.86
24WCB	1.06	1.75	0.250	1.38	4.13	29.998	12	1 1/8-7	27.875	12.75	24.375	11.50	30.62
36WCB	1.52	2.58	0.280	2.38	4.97	44.498	16	1 3/8-6	41.500	16.50	18.375	16.50	44.86
48WCB	1.48	2.70	-	⊙	5.80	56.500	16	1 3/8-6	58.688	25.19	-	23.00	57.09

Size	D <sub>24</sub>	D <sub>25</sub>	D <sub>29</sub>	D <sub>46</sub>	D <sub>43</sub>	G <sup>⊙</sup>	No. H <sub>3</sub> <sup>⊙</sup>	Size H <sub>3</sub> <sup>⊙</sup>	Bolt Circle H <sub>3</sub> <sup>⊙</sup>	H <sub>10</sub>	H <sub>13</sub> <sup>⊙</sup>	J <sub>1</sub>	J <sub>2</sub> <sup>⊙</sup>
8WCB	21	32	6,4	⊙	67	308,0	8	1/2-13	276,2	106	212,7	79	311
14WCB	23	36	6,4	⊙	74	476,3	8	3/4-10	431,8	181	365,1	152	481
18WCB	24	37	6,4	32	80	590,6	12	3/4-10	552,4	279	463,5	216	606
24WCB	27	44	6,4	35	105	761,9	12	1 1/8-7	708,0	324	619,1	292	778
36WCB	39	65	7,1	60	126	1130,2	16	1 3/8-6	1054,1	419	932,1	419	1139
48WCB	38	69	-	⊙	147	1435,0	16	1 3/8-6	1490,7	640	-	584	1450

### SI Dimensions in millimeters

### English Dimensions in inches

Size	No. H <sub>4</sub>	Size H <sub>4</sub>	Bolt Circle H <sub>4</sub>	Size Single Piston O <sub>2</sub> <sup>⊙</sup>	Bolt Circle Single Piston O <sub>2</sub> <sup>⊙</sup>	Size Large Dual Piston O <sub>2</sub> <sup>⊙</sup>	Bolt Circle Large Dual Piston O <sub>2</sub> <sup>⊙</sup>	Size Small Dual Piston O <sub>2</sub> <sup>⊙</sup>	Bolt Circle Small Dual Piston O <sub>2</sub> <sup>⊙</sup>
8WCB	3	1/4-20	3.500	3/8-18	6.63	TBD	TBD	TBD	TBD
14WCB	3	3/8-16	6.500	1/2-14	11.50	1/2-14	13.250	3/8-18	8.250
18WCB	3	3/8-16	9.125	1/2-14	15.25	1/2-14	15.750	3/8-18	11.630
24WCB	6	3/8-16	12.250	1/2-14	18.50	1/2-14	20.500	3/8-18	14.500
36WCB	6	1/2-13	14.500	3/4-14	28.00	3/4-14	28.000	3/8-18	22.250
48WCB	3	3/4-10	24.500	1-11.5	41.500	1-11.5	41.500	0.5-14	31.500

Size	No. H <sub>4</sub>	Size H <sub>4</sub>	Bolt Circle H <sub>4</sub>	Size Single Piston O <sub>2</sub> <sup>⊙</sup>	Bolt Circle Single Piston O <sub>2</sub> <sup>⊙</sup>	Size Large Dual Piston O <sub>2</sub> <sup>⊙</sup>	Bolt Circle Large Dual Piston O <sub>2</sub> <sup>⊙</sup>	Size Small Dual Piston O <sub>2</sub> <sup>⊙</sup>	Bolt Circle Small Dual Piston O <sub>2</sub> <sup>⊙</sup>
8WCB	3	1/4-20	88,9	3/8-18	168	TBD	TBD	TBD	TBD
14WCB	3	3/8-16	165,1	1/2-14	292	1/2-14	337	3/8-18	210
18WCB	3	3/8-16	231,8	1/2-14	387	1/2-14	400	3/8-18	295
24WCB	6	3/8-16	311,2	1/2-14	470	1/2-14	521	3/8-18	368
36WCB	6	1/2-13	444,5	3/4-14	711	3/4-14	711	3/8-18	565
48WCB	3	3/4-10	622,3	1-11,5	1054,1	1-11,5	1054,1	0,5-14	800

### SI Dimensions in millimeters

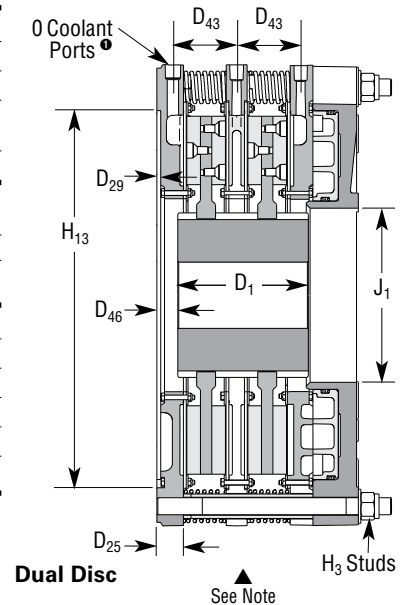
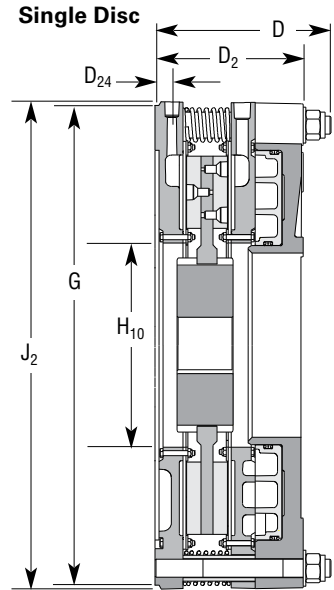

\* Data shown is subject to change. Please consult factory for current dimensional data.

# WCB2 & WCB2 Elements: Dimensional Data

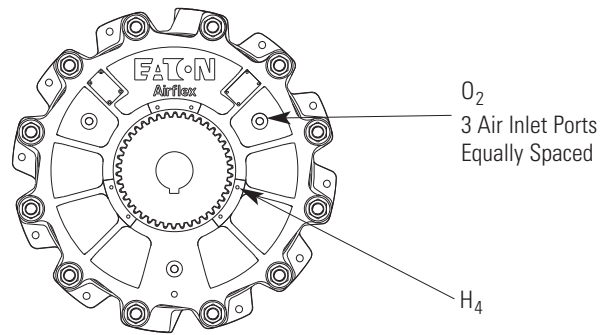

English	Dimensions in inches						
108WCB	1.50	2.56	7.00	1.75	5.69	4	3/8-18
208WCB	1.75	2.63	9.75	4.00	8.31	6	3/8-18
308WCB	2.00	2.50	12.88	7.75	10.95	8	3/8-18
114WCB	2.25	4.50	8.00	2.88	6.59	4	1/2-14
214WCB	2.75	4.38	11.50	4.38	9.50	6	1/2-14
314WCB	2.25	4.50	16.25	8.25	12.39	8	1/2-14
118WCB	2.88	5.56	9.00	2.50	7.32	4	1/2-14
218WCB	3.63	5.63	13.00	5.63	10.66	8	1/2-14
318WCB	4.25	6.13	17.25	9.63	14.00	12	1/2-14
418WCB	4.63	6.13	21.50	12.50	17.34	16	1/2-14
124WCB	3.75	7.25	11.00	3.50	9.26	4	3/4-14
224WCB	4.63	7.38	15.50	8.63	13.31	8	3/4-14
324WCB	5.38	9.38	24.00	13.19	17.38	12	3/4-14
424WCB	6.00	9.38	28.50	16.94	21.43	16	3/4-14
136WCB	5.63	11.25	17.00	5.00	12.07	4	1 1/4-11 1/2
236WCB	6.75	11.75	20.75	9.00	17.04	8	1 1/4-11 1/2
336WCB	7.75	11.75	27.48	13.00	22.00	12	1 1/4-11 1/2
436WCB	8.50	11.75	35.00	18.00	26.99	16	1 1/4-11 1/2
148WCB	7.13	16.13	16.57	5.00	14.42	4	1 1/4-11 1/2
248WCB	8.88	16.81	23.45	11.25	20.07	8	1 1/4-11 1/2
348WCB	10.25	16.81	30.70	16.75	25.71	12	1 1/4-11 1/2
448WCB	11.25	16.81	37.70	22.50	31.36	16	1 1/4-11 1/2

Size	Min.	Max.	D	D <sub>1</sub>	D <sub>2</sub>	No. Coolant Ports <sup>®</sup>	Size
	Bore Range <sup>®</sup>						
	Min.	Max.					
108WCB	38	65	178	44	145	4	3/8-18
208WCB	44	67	248	102	211	6	3/8-18
308WCB	51	64	327	196	278	8	3/8-18
114WCB	57	114	203	73	167	4	1/2-14
214WCB	70	111	292	111	241	6	1/2-14
314WCB	57	114	413	210	315	8	1/2-14
118WCB	73	141	229	64	186	4	1/2-14
218WCB	92	143	330	143	271	8	1/2-14
318WCB	108	156	438	245	356	12	1/2-14
418WCB	117	156	546	318	440	16	1/2-14
124WCB	95	184	279	89	235	4	3/4-14
224WCB	117	187	394	219	338	8	3/4-14
324WCB	137	238	610	335	441	12	3/4-14
424WCB	152	238	724	430	544	16	3/4-14
136WCB	143	286	432	17	307	4	1 1/4-11 1/2
236WCB	171	298	527	229	433	8	1 1/4-11 1/2
336WCB	197	298	698	330	559	12	1 1/4-11 1/2
436WCB	216	298	889	457	686	16	1 1/4-11 1/2
148WCB	181	410	421	127	366	4	1 1/4-11 1/2
248WCB	225	427	596	286	510	8	1 1/4-11 1/2
348WCB	260	427	780	425	653	12	1 1/4-11 1/2
448WCB	286	427	780	572	797	16	1 1/4-11 1/2

## SI Dimensions in millimeters

### Notes:

- Reaction plates for sizes 8 and 14WCB2/WCBD have one inlet and one outlet port located 180° apart. Sizes 18WCB2/WCBD and above have two inlet and two outlet ports located 180° apart.
  - To insure proper cooling, inlet port must be located at the six o'clock position.
  - Tolerance Sizes 8WCB thru 24WCB  
+0.000/-0.003 (+0,00/-0,08)  
36WCB +0.000/-0.005 (+0,00/-0,13)  
48WCB +0.000/-0.005 (+0,00/-0,13)
  - American National Standard for Unified Screw Threads
  - Tolerance +0.003/-0.000 in. (0,08/-0,00 mm)
  - American National Pipe Thread
  - 1.00 in (25 mm) for 108WCB  
1.38 in (35 mm) for 208WCB  
.857 in (4,8 mm) for 308WCB
  - 1.06 in (27 mm) for 114WCB & 314WCB  
1.69 in (43 mm) for 214WCB
  - Maximum bore sizes are based on 2 flat keys, allowable gear hub stresses and torque ratings at 80 psi (5,5 bar).
  - Maximum diameter of "as cast" surfaces
  - 1.96 in (50 mm) for 148WCB  
1.75 in (44 mm) for 248WCB  
1.75 in (44 mm) for 348WCB  
1.75 in (44 mm) for 448WCB
- ▲ Some high torque applications of three or four disc elements require additional torsional support on the cylinder end of the unit. Contact your Airflex representative for more details.

# WCB2 & WCB2 Elements: Technical Data

English				lb-in @ 80 psi		HP	GPM				in <sup>3</sup>					
108WCB	146455	146415	415313	5700	2900	2700	30	3	6.7E-02	0	3	20	2	11	2	10
208WCB	146456	146416	415314	11400	5900	5400	60	6	1.7E-0212	0	7	24	4	12	3	11
308WCB	146457	146417	416457	17100	8900	8100	90	9	7.4E-02	0	10	27	5	14	5	13
114WCB	146458	146418	415454	21500	16000	5400	60	6	2.4E-02	0	13	64	10	48	3	16
214WCB	146459	146419	415302	43000	32100	10800	120	12	6.0E-03	0	27	77	20	58	7	19
314WCB	146460	146420	416303	64500	48200	16300	180	18	2.6E-03	0	40	90	30	68	10	23
118WCB	146461	146421	302813	48800	36400	12300	120	12	1.9E-02	1.9E-01	17	124	13	93	4	31
218WCB	146462	146422	302907	97600	72900	24600	240	24	4.7E-03	9.5E-02	34	141	26	105	9	36
318WCB	146463	146423	413208	146400	109400	37000	360	36	2.1E-03	6.3E-02	51	158	38	118	13	40
418WCB	146464	146424	414111	195200	145800	49300	480	48	1.2E-03	4.8E-02	68	175	51	131	17	44
124WCB	146465	146425	411672	100000	72000	27000	270	27	4.3E-03	1.2E-01	31	204	23	148	9	56
224WCB	146466	146426	410970	200000	145000	54000	540	54	1.1E-03	6.1E-02	62	235	45	170	17	64
324WCB	146467	146427	412433	300000	217000	82000	810	81	4.8E-04	4.1E-02	93	266	68	193	26	73
424WCB	146468	146428	413195	400000	290000	109000	1080	108	2.7E-04	3.0E-02	124	297	90	215	34	82
136WCB	146469	146429	416538	295000	223000	71000	650	65	1.2E-03	8.9E-02	98	441	74	334	24	107
236WCB	146470	146430	416536	590000	446000	143000	1300	130	2.8E-04	5.8E-02	196	539	148	408	47	131
336WCB	146471	146413	416535	885000	670000	214000	1950	195	1.2E-04	3.9E-02	294	637	223	482	71	154
436WCB	146472	146431	416537	1180000	893000	286000	2600	260	6.9E-05	2.9E-02	392	734	297	556	95	178
148WCB	146473	146432	416794	686000	508000	178000	1300	130	1.1E-03	4.6E-02	221	574	163	425	57	149
248WCB	146474	146433	416795	1372000	1016000	356000	2600	260	2.3E-04	3.6E-02	441	795	327	589	115	206
348WCB	146475	146434	416688	2058000	1524000	534000	3900	390	1.0E-04	2.4E-02	662	1016	490	752	172	264
448WCB	146476	146435	416797	2744000	2032000	712000	5200	520	5.6E-05	1.8E-02	883	1236	654	915	229	321

Size	Part Number ①		Gear Part Number	Torque Rating Mr ②			Thermal Rating ③	Water Flow ④	Pressure Drop ⑤		New	Worn	New	Worn	New	Worn			
	WCB2 Single Piston	WCB2 Dual Piston		Single Piston or both Pistons Together	Dual Piston				Engaging Volume		C1	C2	New	Worn	New	Worn	New	Worn	
					Large Piston Only	Small Piston Only			Single Piston or both Pistons Together	Dual Piston									
										Large Piston Only									Small Piston Only
108WCB	146455	146415	415313	644	328	305	22,4	11,4	3,2E-04	0	0,05	0,33	0,03	0,18	0,03	0,16			
208WCB	146456	146416	415314	1288	667	610	44,7	22,7	8,2E-05	0	0,11	0,39	0,07	0,20	0,05	0,18			
308WCB	146457	146417	416457	1932	1006	915	67,2	34,2	7,4E-03	0	0,16	0,44	0,08	0,23	0,08	0,21			
114WCB	146458	146418	415454	2429	1808	610	44,7	22,7	1,2E-04	0	0,21	1,05	0,16	0,79	0,05	0,26			
214WCB	146459	146419	41530	4858	3627	1220	89,5	45,4	2,9E-05	0	0,44	1,26	0,33	0,95	0,11	0,31			
314WCB	146460	146420	416303	7288	5446	1842	134,4	68,4	2,6E-03	0	0,66	1,48	0,49	1,11	0,16	0,38			
118WCB	146461	146421	302813	5514	4113	1390	89,5	45,4	9,1E-05	3,5E-03	0,28	2,03	0,21	1,52	0,07	0,51			
218WCB	146462	146422	302907	11027	8237	2779	179,0	90,9	2,3E-05	1,7E-03	0,56	2,31	0,43	1,72	0,15	0,59			
318WCB	146463	146423	413208	16541	12361	4180	268	136	1,0E-05	1,2E-03	0,84	2,59	0,62	1,93	0,21	0,66			
418WCB	146464	146424	414111	22055	16473	5570	358	182	5,7E-06	8,7E-04	1,11	2,87	0,84	2,15	0,28	0,72			
124WCB	146465	146425	411672	11298	8135	3051	201,3	102,2	2,1E-05	2,2E-03	0,51	3,34	0,38	2,43	0,15	0,92			
224WCB	146466	146426	410970	22597	16383	6101	402,7	204,4	5,2E-06	1,1E-03	1,02	3,85	0,74	2,79	0,28	1,05			
324WCB	146467	146427	412433	33895	24518	9265	604	307	2,3E-06	7,4E-04	1,52	4,36	1,11	3,16	0,43	1,20			
424WCB	146468	146428	413195	45194	32766	12315	805	409	1,3E-06	5,6E-04	2,03	4,87	1,48	3,52	0,56	1,34			
136WCB	146469	146429	416538	33331	25196	8022	484,7	246,1	5,7E-06	1,6E-03	1,61	7,23	1,21	5,47	0,39	1,75			
236WCB	146470	146430	416536	66661	50391	16157	969,4	492,1	1,3E-06	1,1E-03	3,21	8,83	2,43	6,69	0,77	2,15			
336WCB	146471	146413	416535	99992	75700	24179	1454	738	5,9E-07	7,1E-04	4,82	10,44	3,657	7,90	1,16	2,52			
436WCB	146472	146431	416537	133322	100895	32314	1939	984	3,3E-07	5,3E-04	6,42	12,03	4,87	9,11	1,56	2,92			
148WCB	146473	146432	416794	77508	57396	20111	696	4921	5,2E-06	8,4E-04	3,62	9,41	2,67	6,97	0,93	2,44			
248WCB	146474	146433	416795	155015	114793	40223	1939	9840	1,1E-06	6,5E-04	7,23	13,03	5,36	9,65	1,88	3,38			
348WCB	146475	146434	416688	232523	172189	60334	2908	14763	4,8E-07	4,4E-04	10,85	16,65	8,03	12,33	2,82	4,33			
448WCB	146476	146435	416797	310030	229585	80445	3878	19684	2,7E-05	3,3E-03	14,47	20,26	10,72	15,00	3,75	5,26			

SI	Nm @ 5,5 bar		kW	dm <sup>3</sup> /min		dm <sup>3</sup>	
----	--------------	--	----	----------------------	--	-----------------	--

**Notes:**

- 1. Basic part number only. Order gear separately.
  - 2. Exact torque rating is dependent upon applied pressure. Maximum allowable pressure is 150 psi (10,3 bar).
  - 3. Based on a 70°F (21°) fresh water inlet temperature and a maximum 50°F (28°C) rise between inlet and outlet. The maximum allowable outlet temperatures are 150°F (65°C) for fresh water; 165°F (74°C) for 70/30 and 60/40 water glycol mixes; and 170°F (77°C) for 50/50 water glycol mixes. See detailed cooling requirements in the WCB11070 IOM, section 2.4.
  - 4. To insure proper cooling, inlet port must be at the six o'clock position. Flow rates shown are for fresh water, flow rates for water glycol mixes must increase to achieve the ratings in the Thermal Rating column. See detailed cooling requirements in the WCB11070 IOM, section 2.4.
- Maximum allowable outlet pressure — 25 psi  
 Sizes 36-48:  
 Maximum allowable inlet pressure — 60 psi  
 Maximum allowable outlet pressure — 20 psi
- Sizes 8-24:  
 Maximum allowable inlet pressure — 65 psi

# WCB2 & WCB2 Elements: Technical Data

English	rpm		lb		in		lb-ft <sup>2</sup>		in <sup>3</sup>	
108WCB	2150	3400	61	19	3.17	2.05	9	0.8	12	10
208WCB	2150	3400	82	39	4.44	3.38	12	1.5	24	20
308WCB	2150	3400	120	59	5.55	4.55	15	2.33	36	30
114WCB	1260	2100	217	48	3.69	2.42	64	6.4	40	29
214WCB	1260	2100	284	86	5.26	3.83	83	12.6	75	58
314WCB	1260	2100	366	141	6.95	5.23	102	19.5	120	87
118WCB	955	1600	284	91	4.0	2.6	170	20	65	54
218WCB	955	1600	332	210	5.5	4.2	220	40	125	108
318WCB	955	1600	375	260	7.4	6.2	270	60	185	162
418WCB	955	1600	665	383	10	7.6	320	80	245	216
124WCB	715	1200	445	208	5.2	3.3	622	78	160	126
224WCB	715	1200	795	387	7.6	5.7	822	158	320	252
324WCB	715	1200	1000	583	10	8	1022	238	480	378
424WCB	715	1200	1180	767	12.4	10.1	1222	318	640	504
136WCB	475	700	2650	470	6.9	4.3	4922	324	600	337
236WCB	475	700	3250	855	9.5	6.8	6323	667	1135	673
336WCB	475	700	4350	1240	12.11	9.2	7724	1010	1670	1009
436WCB	475	700	5300	1655	14.67	11.8	9125	1353	2205	1345
148WCB	360	600	3694	796	7.86	4.46	12024	1463	700	273
248WCB	360	600	5035	1592	10.69	7.31	16205	2958	1400	546
348WCB	360	600	6378	2383	13.53	10.11	20398	4434	2100	818
448WCB	360	600	7719	3186	16.37	12.95	24583	5916	2800	1091

Size	Maximum Slip Speed <sup>®</sup>	Maximum Freewheeling Speed <sup>®</sup>	Weight		Center of Gravity <sup>®</sup>		Wk <sup>2</sup>		Water Volume	Lining Wear Volume
			Housing Mass	Disc & Gear	Housing	Disc & Gear	Housing	Disc & Gear		
108WCB	2150	3400	28	9	81	52	0,38	0,3	0,2	0,2
208WCB	2150	3400	37	17	113	86	0,51	0,6	0,4	0,3
308WCB	2150	3400	54	27	141	116	0,64	0,04	0,6	0,4
114WCB	1260	2100	98	22	94	61	2,70	0,27	0,7	0,5
214WCB	1260	2100	129	39	134	97	3,50	0,53	1,2	1,0
314WCB	1260	2100	166	64	177	133	4,30	0,82	2,0	1,5
118WCB	955	1600	129	41	102	66	7,16	0,84	1,1	0,9
218WCB	955	1600	150	95	140	107	9,27	1,69	2,1	1,8
318WCB	955	1600	170	118	188	157	11,38	2,53	3,0	2,7
418WCB	955	1600	302	174	254	193	13,48	3,37	4,0	3,5
124WCB	715	1200	202	94	132	84	26,21	3,29	2,6	2,1
224WCB	715	1200	360	175	193	145	34,64	6,66	5,3	4,1
324WCB	715	1200	453	264	254	203	43,07	10,03	7,9	6,2
424WCB	715	1200	534	347	315	257	51,50	13,40	10,5	8,3
136WCB	475	700	1202	213	109	2,2	207,41	13,65	9,9	5,5
236WCB	475	700	1474	388	241	173	266,45	28,11	18,6	11,1
336WCB	475	700	1973	562	308	234	325,49	42,56	27,4	16,6
436WCB	475	700	2404	751	373	300	384,53	57,02	36,2	22,1
148WCB	360	600	1676	361	200	113	506,70	61,65	11,5	4,5
248WCB	360	600	2284	722	272	186	682,89	124,65	22,9	8,9
348WCB	360	600	2893	1081	344	257	859,59	186,85	34,4	13,4
448WCB	360	600	3501	1445	416	329	1035,95	249,31	45,9	17,9

SI	rpm		kg		mm		kg-m <sup>2</sup>		dm <sup>3</sup>	
----	-----	--	----	--	----	--	-------------------	--	-----------------	--

**Notes:**

- 5. Based upon a continuous slip velocity of 4500 fpm (22,9 mps).
- 6. Maximum freewheeling velocity is 7500 fpm (38,1 mps).
- 7. Located from mounting flange surface.
- 8. Absolute volume of cylinder at contact with new and worn friction discs.
- 9. Pressure drop coefficient based on maximum pressure drop across brake.  
Pressure Drop =  $C_1 \times \text{Flow}^2 + C_2 \times \text{Flow}$

# WCB2 WCB D

English	Part number	lb-in at 80psi	lb-in at 90psi	lb-in at 100psi	lb-in at 110psi	lb-in at 120psi	lb-in at 130psi	lb-in at 140psi	lb-in at 150psi
108WCB	146455	5,700	6,199	6,911	7,624	8,336	9,049	9,761	10,474
208WCB	145456	11,400	12,255	13,680	15,105	16,530	17,955	19,380	20,805
308WCB	146457	17,100	18,169	20,306	22,444	24,581	26,719	28,856	30,994
114WCB	146458	21,500	23,381	26,069	28,756	31,444	34,131	36,819	39,506
214WCB	146459	43,000	46,225	51,600	56,975	62,350	67,725	73,100	78,475
314WCB	146460	64,500	68,531	76,594	84,656	92,719	100,781	108,844	116,906
118WCB	146461	48,800	53,070	59,170	65,270	71,370	77,470	83,570	89,670
218WCB	146462	97,600	104,920	117,120	129,320	141,520	153,720	165,920	178,120
318WCB	146463	146,400	155,550	173,850	192,150	210,450	228,750	247,050	265,350
418WCB	146464	195,200	204,960	229,360	253,760	278,160	302,560	326,960	351,360
124WCB	146465	100,000	108,750	121,250	133,750	146,250	158,750	171,250	183,750
224WCB	146466	200,000	215,000	240,000	265,000	290,000	315,000	340,000	365,000
324WCB	146467	300,000	318,750	356,250	393,750	431,250	468,750	506,250	543,750
424WCB	146468	400,000	420,000	470,000	520,000	570,000	620,000	670,000	720,000
136WCB	146469	295,000	320,813	357,688	394,563	431,438	468,313	505,188	542,063
236WCB	146470	590,000	634,250	708,000	781,750	855,500	929,250	1,003,000	1,076,750
336WCB	146471	885,000	940,313	1,050,938	1,161,563	1,272,188	1,382,813	1,493,438	1,604,063
436WCB	146472	1,180,000	1,239,000	1,386,500	1,534,000	1,681,500	1,829,000	1,976,500	2,124,000
148WCB	146473	686,000	746,025	831,775	917,525	1,003,275	1,089,025	1,174,775	1,260,525
248WCB	146474	1,372,000	1,474,900	1,646,400	1,817,900	1,989,400	2,160,900	2,332,400	2,503,900
348WCB	146475	2,058,000	2,186,625	2,443,875	2,701,125	2,958,375	3,215,625	3,472,875	3,730,125
448WCB	146476	2,744,000	2,881,200	3,224,200	3,567,200	3,910,200	4,253,200	4,596,200	4,939,200
Size	Part number	Rated Torque MR	Effective Torque ME	Effective Torque ME	Effective Torque ME	Effective Torque ME	Effective Torque ME	Effective Torque ME	Effective Torque ME
108WCB	146455	644	678	795	865	912	1,029	1,099	1,146
208WCB	145456	1,288	1,340	1,574	1,714	1,808	2,042	2,183	2,276
308WCB	146457	1,932	1,988	2,339	2,550	2,691	3,042	3,253	3,393
114WCB	146458	2,429	2,557	2,999	3,264	3,440	3,882	4,147	4,324
214WCB	146459	4,858	5,052	5,936	6,466	6,819	7,702	8,232	8,585
314WCB	146460	7,288	7,500	8,825	9,620	10,150	11,475	12,270	12,800
118WCB	146461	5,514	5,805	6,807	7,409	7,810	8,812	9,414	9,815
218WCB	146462	11,027	11,468	13,473	14,676	15,478	17,483	18,686	19,488
318WCB	146463	16,541	17,022	20,030	21,834	23,037	26,045	27,849	29,052
418WCB	146464	22,055	22,416	26,426	28,832	30,436	34,446	36,852	38,456
124WCB	146465	11,298	11,894	13,948	15,180	16,002	18,056	19,289	20,110
224WCB	146466	22,597	23,501	27,609	30,075	31,718	35,827	38,292	39,935
324WCB	146467	33,895	34,881	41,044	44,741	47,206	53,369	57,067	59,532
424WCB	146468	45,194	45,934	54,151	59,081	62,368	70,585	75,515	78,802
136WCB	146469	33,331	35,088	41,149	44,785	47,209	53,269	56,905	59,329
236WCB	146470	66,661	69,327	81,448	88,720	93,568	105,688	112,960	117,808
336WCB	146471	99,992	102,901	121,081	131,989	139,262	157,442	168,350	175,622
436WCB	146472	133,322	135,504	159,744	174,288	183,984	208,225	222,769	232,465
148WCB	146473	77,508	81,595	95,687	104,143	109,780	123,872	132,327	137,964
248WCB	146474	155,015	161,216	189,400	206,311	217,585	245,769	262,680	273,954
348WCB	146475	232,523	239,287	281,564	306,930	323,841	366,118	391,484	408,395
448WCB	146476	310,030	315,103	371,472	405,294	427,841	484,210	518,032	540,580
SI		Nm at 5.5bar	Nm at 6.0bar	Nm at 7.0bar	Nm at 7.6bar	Nm at 8.0bar	Nm at 9.0bar	Nm at 9.6bar	Nm at 10.0bar

- Basic part number only. Order gear separately.
- Exact torque rating is dependent upon applied pressure. Maximum allowable pressure is 150 psi (10 bar) when standard friction material is used. Maximum allowed pressure is 120 psi when alternate friction material is used.
- Torque rating for the WCB D is based on the use of the large and small pistons together.

- $ME = ((Po - Pp) / Pr) * MR$   
 ME = Effective Torque  
 MR = Rated Torque  
 Po = Operating Pressure  
 Pp = Parasitic Pressure  
 Pr = Rated Pressure
- Please contact Eaton if you need any further information.



# The Eaton Advantage

## World Class, Worldwide

Eaton supports Airflex products with distributor locations in over 65 countries worldwide. Parts, experienced sales engineers and instant access to Eaton's power transmission knowledge base and manufacturing resources are as close as your local Eaton Airflex representative.

## Engineered to Last

Eaton combines 70 years of industrial clutch and brake experience with ground breaking, innovative and proven product designs to deliver efficient and reliable application solutions you can count on. All Airflex products are backed by service to ensure complete satisfaction.

## Custom Solutions

Eaton's Application Engineering team is available to work with your engineers to optimize an application solution. From a single component to a complete system solution, the Eaton Application Engineering and Sales teams are ready to help you get the job done right the first time and every time.

To learn more about how Airflex products can meet your application requirements, visit [www.eaton.com/airflex](http://www.eaton.com/airflex) or call 1-800-Airflex (247-3539)

Providing the **highest reliability** in harsh duty conditions  
for the **lowest total life cycle cost**

## Genuine Eaton Airflex Replacement Parts

When you purchase an Eaton product, you expect a quality solution that will keep your application running at peak performance under the harshest operating conditions. Eaton continuously strives to produce the highest quality product available because that is what customers require.

There are various choices in the market for friction material and other replacement parts, but why risk performance. Genuine Airflex replacement parts are an exact fit and will ensure your clutch or brake will continue to perform to original specifications for its entire operating life.

To find out more about genuine Airflex replacement parts, contact your Eaton Airflex representative or an Airflex authorized distributor.