

Airflex® Water-Cooled Brakes

Section D

WCB2/D Description	159
WCB2/D Elements	161
WCB2/D Technical Data	163
WCS Description	165
WCS Elements	167
WCS Technical Data	169
WCSB Description	171
WCSB Elements	173
WCSB Technical Data	175
Selection Procedure	177
Cooling Requirements	178
Coolant System	179

Airflex® Water Cooled Brakes

WCB2 and WCBD

Section D

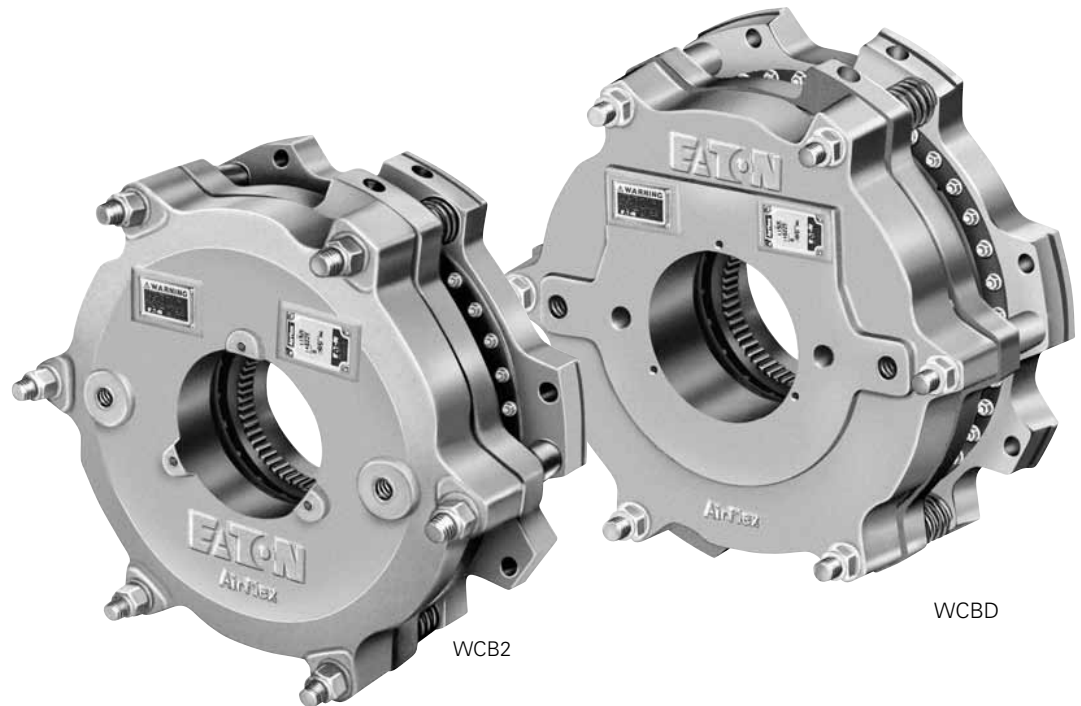

WHERE USED

- Drilling rigs
- Dynamometers
- Logging equipment
- Marine mooring systems
- Slip clutches
- Tension brakes
- Unwind stands

WCB elements are disc type, externally cooled units. They are designed to absorb and dissipate the thermal loads associated with the most severe clutch and brake applications. The WCB friction couple was developed specifically for continuous slip service and has a dynamic coefficient of friction that is greater than its static coefficient of friction. Also available, special high coefficient linings, which provide 50% higher torque than standard friction linings and provide a 1:1 dynamic to static torque ratio.

Element construction and operation is illustrated in the figure on page 3. Pressurizing the cylinder causes the piston to clamp the friction disc between the water jackets. Heat generated at the friction interface is quickly transferred to the circulating coolant.

Element sizes are indicated by the number of friction discs and the disc diameter in inches. For instance, size 224WCB has two (2) friction discs 24 inches in diameter.

Features:

Patented piston design

Single or dual piston provides wider range of applied tension with greater control.

Drop in powerhead package

Standard single piston elements can be retrofitted with a dual piston powerhead to provide increased control.

Split wear spacers

The split wear spacers allow for wear adjustment without disassembly of the brake to minimize downtime and maintenance costs.

Unique friction couple

A specially formulated friction material, interfacing with a copper alloy surface, eliminates the stick-slip characteristic associated with ordinary frictional devices.

Rapid heat dissipation

The copper interface conducts heat rapidly to the circulating coolant.

Open or closed loop coolant systems

The element works equally well with open or closed loop circulating systems. On mobile equipment, the engine's cooling system can be tapped to provide coolant to the element.

Optional corrosion protection

For marine environment applications, protective coatings are available to minimize corrosion.

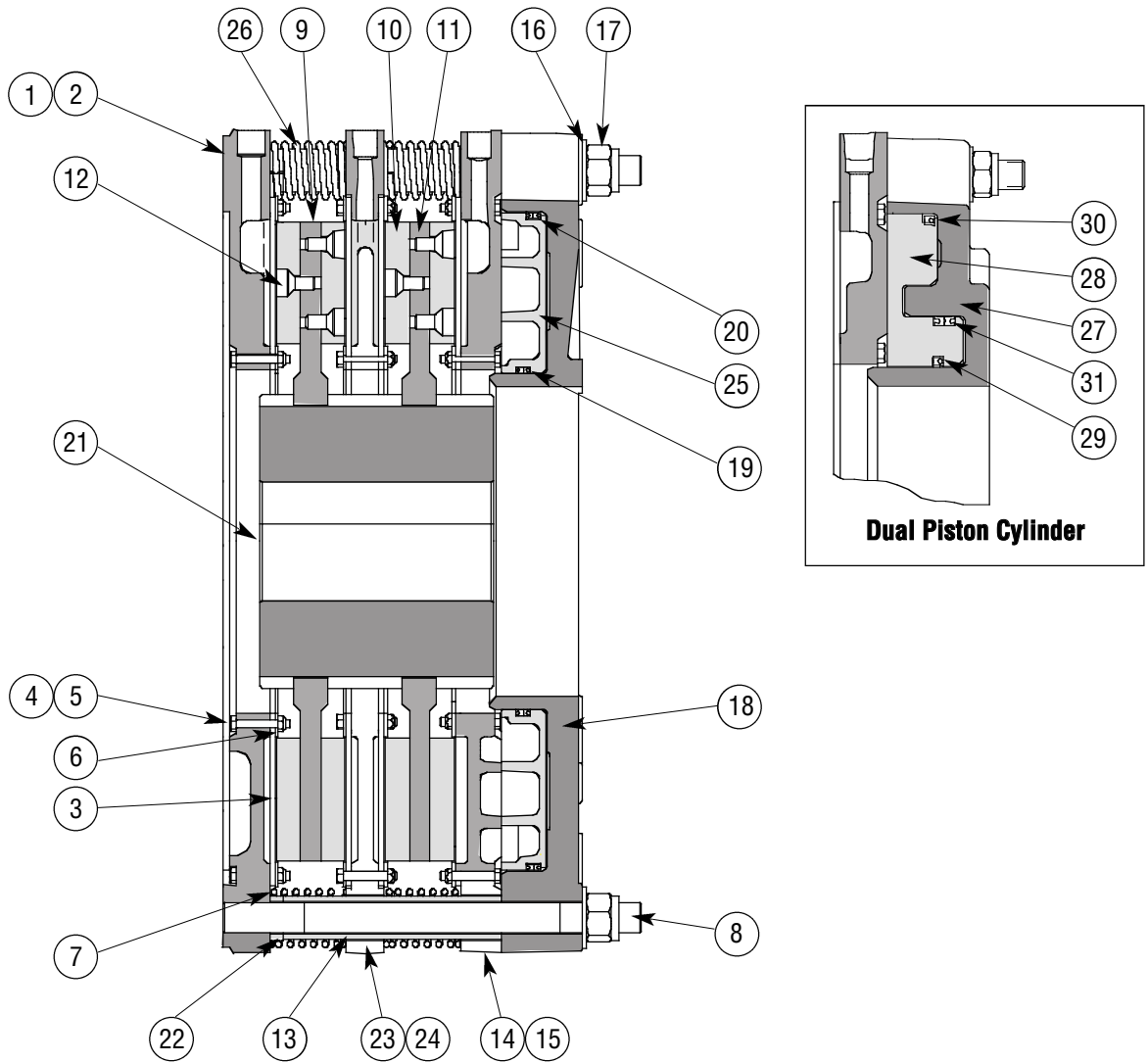

WCB2 & WCBD Component Parts

Item	Description	Item	Description
1	Mounting Flange Sub-Assembly	17	Lock Nut
2	Mounting Flange	18	Cylinder
3	Wear Plate	19	Inner Seal
4	Hex Head Screw	20	Outer Seal
5	Locknut	21	Gear
6	Inner Support Ring	22	Wear Spacer
7	Outer Support Ring	23	Reaction Plate Sub-Assembly
8	Stud	24	Reaction Plate
9	Friction Disc Sub-Assembly	25	Piston
10	Friction Disc	26	Release Spring
11	Friction Disc Core	27	Dual Piston Cylinder
12	Flat Head Screw	28	Dual Piston
13	Clamp Tube	29	Dual Piston Inner Seal
14	Pressure Plate Sub-Assembly	30	Dual Piston Outer Seal
15	Pressure Plate	31	Dual Piston Intermediate Seal
16	Flat Washer		

Note:

Dual disc unit shown. Other multi-disc units are similar. Items 23 and 24 are not required for single disc units.

WCB2 & WCBD Elements

Dimensional Data*

Section D

Mounting Bolt Circles [⊙]

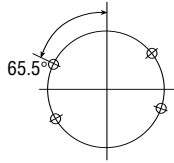

Coolant Inlet Port
8WCB
(4) 0.531 (13,5)Ø Dia.
Mounting holes based on 8 equally spaced as shown on 11.125 (282,5) bolt circle

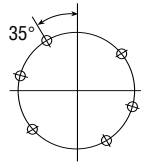

Coolant Inlet Port
14WCB
(6) 0.656 (16,7)Ø Dia. Mounting holes based on 8 equally spaced as shown on 17.500 (444,5) bolt circle

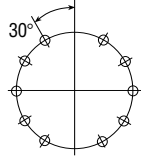

Coolant Inlet Port
18WCB
(10) 0.656 (16,75)Ø Dia. Mounting holes based on 12 equally spaced as shown on 22.000 (558,8) bolt circle

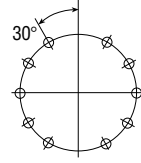

Coolant Inlet Port
24WCB
(10) 0.656 (16,75)Ø Dia. Mounting holes based on 12 equally spaced as shown on 28.750(730,3) bolt circle

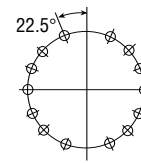

Coolant Inlet Port
36WCB
(14) 1.062 (27,0)Ø Dia. Mounting holes based on 16 equally spaced as shown on 42.000 (1066,8) bolt circle

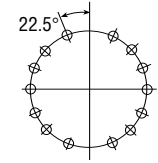

Coolant Inlet Port
48WCB
(14) 1.438 (36,5)Ø Dia. Mounting holes based on 16 equally spaced as shown on 54.000 (1371,6) bolt circle

English Dimensions in inches

8WCB	0.81	1.25	0.250	⊙	2.62	12.125	8	1/2-13	10.875	4.12	8.375	3.12	12.24
14WCB	0.91	1.41	0.250	⊙	2.90	18.750	8	3/4-10	17.000	7.12	14.375	6.00	18.94
18WCB	0.93	1.47	0.250	1.25	3.14	23.25	12	3/4-10	21.750	11.00	18.250	8.50	23.86
24WCB	1.06	1.75	0.250	1.38	4.13	29.998	12	1 1/8-7	27.875	12.75	24.375	11.50	30.62
36WCB	1.52	2.58	0.280	2.38	4.97	44.498	16	1 3/8-6	41.500	16.50	18.375	16.50	44.86
48WCB	1.48	2.70	-	⊙	5.80	56.50	16	1 3/8-6	58.688	25.19	-	23.00	57.09

Size	D ₂₄	D ₂₅	D ₂₉	D ₄₆	D ₄₃	G [⊙]	No. Size		Bolt Circle	H ₁₀	H ₁₃ [⊙]	J ₁	J ₂ [⊙]
							H ₃ [⊙]	H ₃ [⊙]					
8WCB	21	32	6,4	⊙	67	308,0	8	1/2-13	276,2	106	212,7	79	311
14WCB	23	36	6,4	⊙	74	476,3	8	3/4-10	431,8	181	365,1	152	481
18WCB	24	37	6,4	32	80	590,6	12	3/4-10	552,4	279	463,5	216	606
24WCB	27	44	6,4	35	105	761,9	12	1 1/8-7	708,0	324	619,1	292	778
36WCB	39	65	7,1	60	126	1130,2	16	1 3/8-6	1054,1	419	932,1	419	1139
48WCB	38	69	-	⊙	147	1435,0	16	1 3/8-6	1490,7	640	-	584	1450

SI Dimensions in millimeters

English Dimensions in inches

8WCB	3	1/4-20	3.500	3/8-18	6.63	TBD	TBD	TBD	TBD
14WCB	3	3/8-16	6.500	1/2-14	11.50	1/2-14	13.250	3/8-18	8.250
18WCB	3	3/8-16	9.125	1/2-14	15.25	1/2-14	15.750	3/8-18	11.630
24WCB	6	3/8-16	12.250	1/2-14	18.50	1/2-14	20.500	3/8-18	14.500
36WCB	6	1/2-13	14.500	3/4-14	28.00	3/4-14	28.000	3/8-18	22.250
48WCB	3	3/4-10	24.500	1-11.5	41.500	1-11.5	41.500	0.5-14	31.500

Size	No.	Size	Bolt Circle	Single Piston O ₂ [⊙]		Dual Piston O ₂ [⊙]			
				Size	Bolt Circle	Large		Small	
						Large Size	Large Bolt Circle	Small Size	Small Bolt Circle
8WCB	3	1/4-20	88,9	3/8-18	168	TBD	TBD	TBD	TBD
14WCB	3	3/8-16	165,1	1/2-14	292	1/2-14	337	3/8-18	210
18WCB	3	3/8-16	231,8	1/2-14	387	1/2-14	400	3/8-18	295
24WCB	6	3/8-16	311,2	1/2-14	470	1/2-14	521	3/8-18	368
36WCB	6	1/2-13	444,5	3/4-14	711	3/4-14	711	3/8-18	565
48WCB	3	3/4-10	622,3	1-11,5	1054,1	1-11,5	1054,1	0,5-14	800

SI Dimensions in millimeters

Single Disc

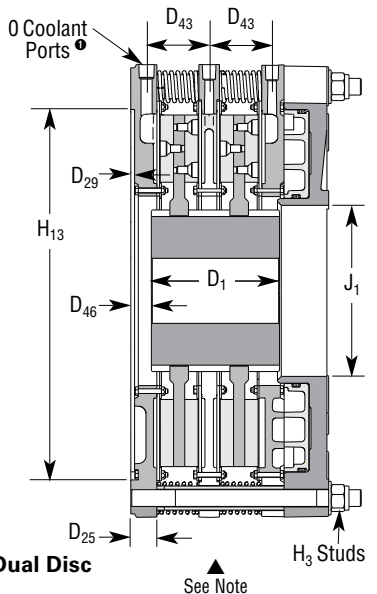
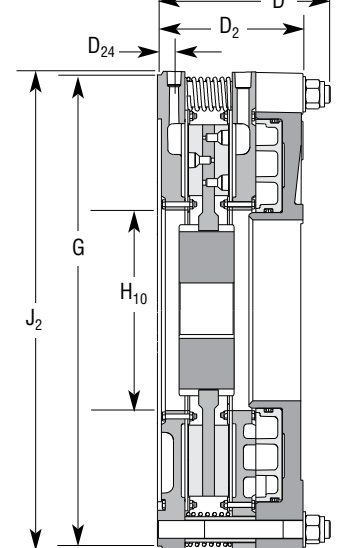

* Data shown is subject to change. Please consult factory for current dimensional data.

WCB2 & WCB2 Elements

Dimensional Data

Section D

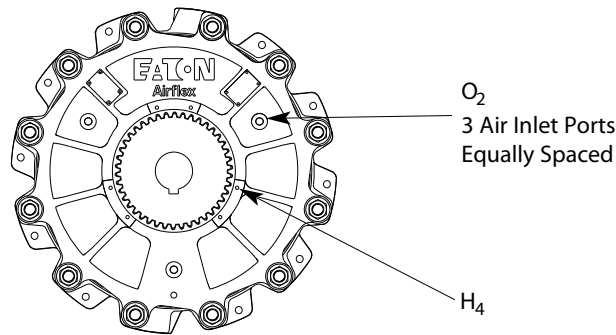

English Dimensions in inches

English	1.50	2.56	7.00	1.75	5.69	4	3/8-18 NTP
108WCB	1.50	2.56	7.00	1.75	5.69	4	3/8-18 NTP
208WCB	1.75	2.63	9.75	4.00	8.31	6	3/8-18 NTP
308WCB	2.00	2.50	12.88	7.75	10.95	8	3/8-18 NTP
114WCB	2.25	4.50	8.00	2.88	6.59	4	1/2-14 NTP
214WCB	2.75	4.38	11.50	4.38	9.50	6	1/2-14 NTP
314WCB	2.25	4.50	16.25	8.25	12.39	8	1/2-14 NTP
118WCB	2.88	5.56	9.00	2.50	7.32	4	1/2-14 NTP
218WCB	3.63	5.63	13.00	5.63	10.66	8	1/2-14 NTP
318WCB	4.25	6.13	17.25	9.63	14.00	12	1/2-14 NTP
418WCB	4.63	6.13	21.50	12.50	17.34	16	1/2-14 NTP
124WCB	3.75	7.25	11.00	3.50	9.26	4	3/4 SAE ORB
224WCB	4.63	7.38	15.50	8.63	13.31	8	3/4 SAE ORB
324WCB	5.38	9.38	24.00	13.19	17.38	12	3/4 SAE ORB
424WCB	6.00	9.38	28.50	16.94	21.43	16	3/4 SAE ORB
136WCBEP	5.63	11.25	17.00	5.00	12.18	4	1 1/4 SAE ORB
236WCBEP	6.75	11.75	20.75	9.00	17.24	8	1 1/4 SAE ORB
336WCBEP	7.75	11.75	27.48	13.00	22.30	12	1 1/4 SAE ORB
436WCBEP	8.50	11.75	35.00	18.00	27.39	16	1 1/4 SAE ORB
148WCB	7.13	16.13	16.57	5.00	14.42	4	1 1/4 SAE ORB
248WCB	8.88	16.81	23.45	11.25	20.07	8	1 1/4 SAE ORB
348WCB	10.25	16.81	30.70	16.75	25.71	12	1 1/4 SAE ORB
448WCB	11.25	16.81	37.70	22.50	31.36	16	1 1/4 SAE ORB

Notes:

1. Reaction plates for sizes 8 and 14WCB2/WCBD have one inlet and one outlet port located 180° apart. Sizes 18WCB2/WCBD and above have two inlet and two outlet ports located 180° apart.
2. To insure proper cooling, inlet port must be located at the six o'clock position.
3. Tolerance Sizes 8WCB thru 24WCB
+0.000/-0.003 (+0,00/-0,08)
36WCB +0.000/-0.005 (+0,00/-0,13)
48WCB +0.000/-0.005 (+0,00/-0,13)
4. American National Standard for Unified Screw Threads
5. Tolerance +0.003/-0.000 in. (0,08/-0,00 mm)
6. American National Pipe Thread
7. 1.00 in (25 mm) for 108WCB
1.38 in (35 mm) for 208WCB
.857 in (4,8 mm) for 308WCB
8. 1.06 in (27 mm) for 114WCB & 314WCB
1.69 in (43 mm) for 214WCB
9. Maximum bore sizes are based on 2 flat keys, allowable gear hub stresses and torque ratings at 80 psi (5,5 bar).
10. Maximum diameter of "as cast" surfaces
11. 1.96 in (50 mm) for 148WCB
1.75 in (44 mm) for 248WCB
1.75 in (44 mm) for 348WCB
1.75 in (44 mm) for 448WCB

Size	Min. Max. Bore Range [®]		D	D ₁	D ₂	No. O Coolant Ports [®]	Size
	Min.	Max.					
108WCB	38	65	178	44	145	4	3/8-18 NPT
208WCB	44	67	248	102	211	6	3/8-18 NPT
308WCB	51	64	327	196	278	8	3/8-18 NPT
114WCB	57	114	203	73	167	4	1/2-14 NPT
214WCB	70	111	292	111	241	6	1/2-14 NPT
314WCB	57	114	413	210	315	8	1/2-14 NPT
118WCB	73	141	229	64	186	4	1/2-14 NPT
218WCB	92	143	330	143	271	8	1/2-14 NPT
318WCB	108	156	438	245	356	12	1/2-14 NPT
418WCB	117	156	546	318	440	16	1/2-14 NPT
124WCB	95	184	279	89	235	4	3/4 SAE ORB
224WCB	117	187	394	219	338	8	3/4 SAE ORB
324WCB	137	238	610	335	441	12	3/4 SAE ORB
424WCB	152	238	724	430	544	16	3/4 SAE ORB
136WCBEP	143	286	432	127	309	4	1 1/4 SAE ORB
236WCBEP	171	298	527	229	438	8	1 1/4 SAE ORB
336WCBEP	197	298	698	330	566	12	1 1/4 SAE ORB
436WCBEP	216	298	889	457	696	16	1 1/4 SAE ORB
148WCB	181	410	421	127	366	4	1 1/4 SAE ORB
248WCB	225	427	596	286	510	8	1 1/4 SAE ORB
348WCB	260	427	780	425	653	12	1 1/4 SAE ORB
448WCB	286	427	780	572	797	16	1 1/4 SAE ORB

SI Dimensions in millimeters

▲ Some high torque applications of three or four disc elements require additional torsional support on the cylinder end of the unit. Contact your Airflex representative for more details.

WCB2 & WCBD Elements

Technical Data

Section D

English				lb-in @ 80 psi			HP	GPM			in ³					
108WCB	146455	146415	415313	5700	2900	2700	30	3	6.7E-02	0	3	20	2	11	2	10
208WCB	146456	146416	415314	11400	5900	5400	60	6	1.7E-0212	0	7	24	4	12	3	11
308WCB	146457	146417	416457	17100	8900	8100	90	9	7.4E-02	0	10	27	5	14	5	13
114WCB	146458	146418	415454	21500	16000	5400	60	6	2.4E-02	0	13	64	10	48	3	16
214WCB	146459	146419	415302	43000	32100	10800	120	12	6.0E-03	0	27	77	20	58	7	19
314WCB	146460	146420	416303	64500	48200	16300	180	18	2.6E-03	0	40	90	30	68	10	23
118WCB	146461	146421	302813	48800	36400	12300	120	12	1.9E-02	1.9E-01	17	124	13	93	4	31
218WCB	146462	146422	302907	97600	72900	24600	240	24	4.7E-03	9.5E-02	34	141	26	105	9	36
318WCB	146463	146423	413208	146400	109400	37000	360	36	2.1E-03	6.3E-02	51	158	38	118	13	40
418WCB	146464	146424	414111	195200	145800	49300	480	48	1.2E-03	4.8E-02	68	175	51	131	17	44
124WCB	146465	146425	411672	100000	72000	27000	270	27	4.3E-03	1.2E-01	31	204	23	148	9	56
224WCB	146466	146426	410970	200000	145000	54000	540	54	1.1E-03	6.1E-02	62	235	45	170	17	64
324WCB	146467	146427	412433	300000	217000	82000	810	81	4.8E-04	4.1E-02	93	266	68	193	26	73
424WCB	146468	146428	413195	400000	290000	109000	1080	108	2.7E-04	3.0E-02	124	297	90	215	34	82
136WCBEP	146535	146534	416538	295000	223000	71000	780	78	1.2E-03	8.9E-02	98	441	74	334	24	107
236WCBEP	146536	146538	416536	590000	446000	143000	1560	156	2.8E-04	5.8E-02	196	539	148	408	47	131
336WCBEP	146540	146542	416535	885000	670000	214000	2340	234	1.2E-04	3.9E-02	294	637	223	482	71	154
436WCBEP	146545	146547	416537	1180000	893000	286000	3120	312	6.9E-05	2.9E-02	392	734	297	556	95	178
148WCB	146473	146432	416794	686000	508000	178000	1300	130	1.1E-03	4.6E-02	221	574	163	425	57	149
248WCB	146474	146433	416795	1372000	1016000	356000	2600	260	2.3E-04	3.6E-02	441	795	327	589	115	206
348WCB	146475	146434	416688	2058000	1524000	534000	3900	390	1.0E-04	2.4E-02	662	1016	490	752	172	264
448WCB	146476	146435	416797	2744000	2032000	712000	5200	520	5.6E-05	1.8E-02	883	1236	654	915	229	321

Size	Part Number [Ⓢ]		Gear Part Number	Torque Rating Mr [Ⓢ]			Thermal Rating [Ⓢ]	Water Flow	Pressure Drop [Ⓢ]		C1	C2	New	Worn	New	Worn	New	Worn
	WCB2 Single Piston	WCBD Dual Piston		Single Piston or both Pistons Together	Dual Piston				Engaging Volume [Ⓢ]									
					Large Piston Only	Small Piston Only			Single Piston or both Pistons Together	Dual Piston			New	Worn	New	Worn		
										Large Piston Only							Small Piston Only	
108WCB	146455	146415	415313	644	328	305	22,4	11,4	3,2E-04	0	0,05	0,33	0,03	0,18	0,03	0,16		
208WCB	146456	146416	415314	1288	667	610	44,7	22,7	8,2E-05	0	0,11	0,39	0,07	0,20	0,05	0,18		
308WCB	146457	146417	416457	1932	1006	915	67,2	34,2	7,4E-03	0	0,16	0,44	0,08	0,23	0,08	0,21		
114WCB	146458	146418	415454	2429	1808	610	44,7	22,7	1,2E-04	0	0,21	1,05	0,16	0,79	0,05	0,26		
214WCB	146459	146419	415302	4858	3627	1220	89,5	45,4	2,9E-05	0	0,44	1,26	0,33	0,95	0,11	0,31		
314WCB	146460	146420	416303	7288	5446	1842	134,4	68,4	2,6E-03	0	0,66	1,48	0,49	1,11	0,16	0,38		
118WCB	146461	146421	302813	5514	4113	1390	89,5	45,4	9,1E-05	3,5E-03	0,28	2,03	0,21	1,52	0,07	0,51		
218WCB	146462	146422	302907	11027	8237	2779	179,0	90,9	2,3E-05	1,7E-03	0,56	2,31	0,43	1,72	0,15	0,59		
318WCB	146463	146423	413208	16541	12361	4180	268	136	1,0E-05	1,2E-03	0,84	2,59	0,62	1,93	0,21	0,66		
418WCB	146464	146424	414111	22055	16473	5570	358	182	5,7E-06	8,7E-04	1,11	2,87	0,84	2,15	0,28	0,72		
124WCB	146465	146425	411672	11298	8135	3051	201,3	102,2	2,1E-05	2,2E-03	0,51	3,34	0,38	2,43	0,15	0,92		
224WCB	146466	146426	410970	22597	16383	6101	402,7	204,4	5,2E-06	1,1E-03	1,02	3,85	0,74	2,79	0,28	1,05		
324WCB	146467	146427	412433	33895	24518	9265	604	307	2,3E-06	7,4E-04	1,52	4,36	1,11	3,16	0,43	1,20		
424WCB	146468	146428	413195	45194	32766	12315	805	409	1,3E-06	5,6E-04	2,03	4,87	1,48	3,52	0,56	1,34		
136WCBEP	146535	146534	416538	33331	25196	8022	581,6	295,3	5,7E-06	1,6E-03	1,61	7,23	1,21	5,47	0,39	1,75		
236WCBEP	146536	146538	416536	66661	50391	16157	1163,3	590,5	1,3E-06	1,1E-03	3,21	8,83	2,43	6,69	0,77	2,15		
336WCBEP	146540	146542	416535	99992	75700	24179	1744,9	885,8	5,9E-07	7,1E-04	4,82	10,44	3,657	7,90	1,16	2,52		
436WCBEP	146545	146547	416537	133322	100895	32314	2326,6	1181	3,3E-07	5,3E-04	6,42	12,03	4,87	9,11	1,56	2,92		
148WCB	146473	146432	416794	77508	57396	20111	696	4921	5,2E-06	8,4E-04	3,62	9,41	2,67	6,97	0,93	2,44		
248WCB	146474	146433	416795	155015	114793	40223	1939	9840	1,1E-06	6,5E-04	7,23	13,03	5,36	9,65	1,88	3,38		
348WCB	146475	146434	416688	232523	172189	60334	2908	14763	4,8E-07	4,4E-04	10,85	16,65	8,03	12,33	2,82	4,33		
448WCB	146476	146435	416797	310030	229585	80445	3878	19684	2,7E-05	3,3E-03	14,47	20,26	10,72	15,00	3,75	5,26		

SI	Nm @ 5,5 bar			kW	dm ³ /min			dm ³		
----	--------------	--	--	----	----------------------	--	--	-----------------	--	--

Notes:

- Basic part number only. Order gear separately.
 - Exact torque rating is dependent upon applied pressure. Maximum allowable pressure is 150 psi (10,3 bar).
 - Based on a 70°F (21°) fresh water inlet temperature and a maximum 50°F (28°C) rise between inlet and outlet. The maximum allowable outlet temperatures are 150°F (65°C) for fresh water; 165°F (74°C) for 70/30 and 60/40 water glycol mixes; and 170°F (77°C) for 50/50 water glycol mixes. See detailed cooling requirements in the WCB11070 IOM, section 2.4.
 - To insure proper cooling, inlet port must be at the six o'clock position. Flow rates shown are for fresh water, flow rates for water glycol mixes must increase to achieve the ratings in the Thermal Rating column. See detailed cooling requirements in the WCB11070 IOM, section 2.4.
- Maximum allowable outlet pressure — 25 psi
 Sizes 36-48:
 Maximum allowable inlet pressure — 60 psi
 Maximum allowable outlet pressure — 20 psi
- Sizes 8-24:
 Maximum allowable inlet pressure — 65 psi

WCB2 & WCBD Elements

Technical Data

Section D

English	rpm		lb		in		lb·ft ²		in ³	
108WCB	2150	3400	61	19	3.17	2.05	9	0.8	12	10
208WCB	2150	3400	82	39	4.44	3.38	12	1.5	24	20
308WCB	2150	3400	120	59	5.55	4.55	15	2.33	36	30
114WCB	1260	2100	217	48	3.69	2.42	64	6.4	40	29
214WCB	1260	2100	284	86	5.26	3.83	83	12.6	75	58
314WCB	1260	2100	366	141	6.95	5.23	102	19.5	120	87
118WCB	955	1600	284	91	4.0	2.6	170	20	65	54
218WCB	955	1600	332	210	5.5	4.2	220	40	125	108
318WCB	955	1600	375	260	7.4	6.2	270	60	185	162
418WCB	955	1600	665	383	10	7.6	320	80	245	216
124WCB	715	1200	445	208	5.2	3.3	622	78	160	126
224WCB	715	1200	795	387	7.6	5.7	822	158	320	252
324WCB	715	1200	1000	583	10	8	1022	238	480	378
424WCB	715	1200	1180	767	12.4	10.1	1222	318	640	504
136WCB	475	700	2650	470	6.9	4.3	4922	324	600	337
236WCB	475	700	3250	855	9.5	6.8	6323	667	1135	673
336WCB	475	700	4350	1240	12.11	9.2	7724	1010	1670	1009
436WCB	475	700	5300	1655	14.67	11.8	9125	1353	2205	1345
148WCB	360	600	3694	796	7.86	4.46	12024	1463	700	273
248WCB	360	600	5035	1592	10.69	7.31	16205	2958	1400	546
348WCB	360	600	6378	2383	13.53	10.11	20398	4434	2100	818
448WCB	360	600	7719	3186	16.37	12.95	24583	5916	2800	1091

Size	Maximum Slip Speed ⁵	Maximum Freewheeling Speed ⁶	Weight		Center of Gravity ⁷		Wk ²		Water Volume	Lining Wear Volume
			Housing Mass	Disc & Gear	Housing Center of Gravity	Disc & Gear	Housing J	Disc & Gear		
108WCB	2150	3400	28	9	81	52	0,38	0,3	0,2	0,2
208WCB	2150	3400	37	17	113	86	0,51	0,6	0,4	0,3
308WCB	2150	3400	54	27	141	116	0,64	0,04	0,6	0,4
114WCB	1260	2100	98	22	94	61	2,70	0,27	0,7	0,5
214WCB	1260	2100	129	39	134	97	3,50	0,53	1,2	1,0
314WCB	1260	2100	166	64	177	133	4,30	0,82	2,0	1,5
118WCB	955	1600	129	41	102	66	7,16	0,84	1,1	0,9
218WCB	955	1600	150	95	140	107	9,27	1,69	2,1	1,8
318WCB	955	1600	170	118	188	157	11,38	2,53	3,0	2,7
418WCB	955	1600	302	174	254	193	13,48	3,37	4,0	3,5
124WCB	715	1200	202	94	132	84	26,21	3,29	2,6	2,1
224WCB	715	1200	360	175	193	145	34,64	6,66	5,3	4,1
324WCB	715	1200	453	264	254	203	43,07	10,03	7,9	6,2
424WCB	715	1200	534	347	315	257	51,50	13,40	10,5	8,3
136WCB	475	700	1202	213	109	2,2	207,41	13,65	9,9	5,5
236WCB	475	700	1474	388	241	173	266,45	28,11	18,6	11,1
336WCB	475	700	1973	562	308	234	325,49	42,56	27,4	16,6
436WCB	475	700	2404	751	373	300	384,53	57,02	36,2	22,1
148WCB	360	600	1676	361	200	113	506,70	61,65	11,5	4,5
248WCB	360	600	2284	722	272	186	682,89	124,65	22,9	8,9
348WCB	360	600	2893	1081	344	257	859,59	186,85	34,4	13,4
448WCB	360	600	3501	1445	416	329	1035,95	249,31	45,9	17,9

SI	rpm	kg	mm	kg·m ²	dm ³
----	-----	----	----	-------------------	-----------------

Notes:

- Based upon a continuous slip velocity of 4500 fpm (22,9 mps).
- Maximum freewheeling velocity is 7500 fpm (38,1 mps).
- Located from mounting flange surface.
- Absolute volume of cylinder at contact with new and worn friction discs.
- Pressure drop coefficient based on maximum pressure drop across brake.
Pressure Drop = C₁ × Flow² + C₂ × Flow

Airflex® WCS Description

Section D

WCS elements are disc type, externally cooled, spring applied units. They are designed to absorb and dissipate the thermal loads associated with the most severe braking and tensioning applications. The WCS friction couple was developed specifically for continuous slip service and has a dynamic coefficient of friction which is larger than its static coefficient of friction. Special high coefficient linings are also available which provide 50% higher torque than standard friction linings and provide a 1:1 dynamic to static torque ratio.

Element construction and operation is illustrated in the figure. Pressurizing the unit compresses the brake springs and withdraws the water jackets from the brake discs. Heat generated at the friction interfaces is quickly transferred to the circulating coolant.

Element sizes are indicated by the number of friction discs and the disc diameter in inches. For instance, size 224WCS has two friction discs 24 inches in diameter.

Features:

Unique friction couple.

A specially formulated friction material, interfacing with a copper alloy surface, eliminates the stick-slip characteristic associated with ordinary frictional devices.

Rapid heat dissipation.

The copper interface conducts heat rapidly to the circulating coolant.

Open or closed loop coolant systems.

The element works equally well with open or closed loop circulating systems. On mobile equipment, the engine's cooling system can be tapped to provide coolant to the element.

Optional corrosion protection

For marine environment applications, protective coatings are available to minimize corrosion.



Where used:

- Logging equipment
- Marine Mooring Systems
- Drilling Rigs

Airflex® WCS Component Parts

Section D

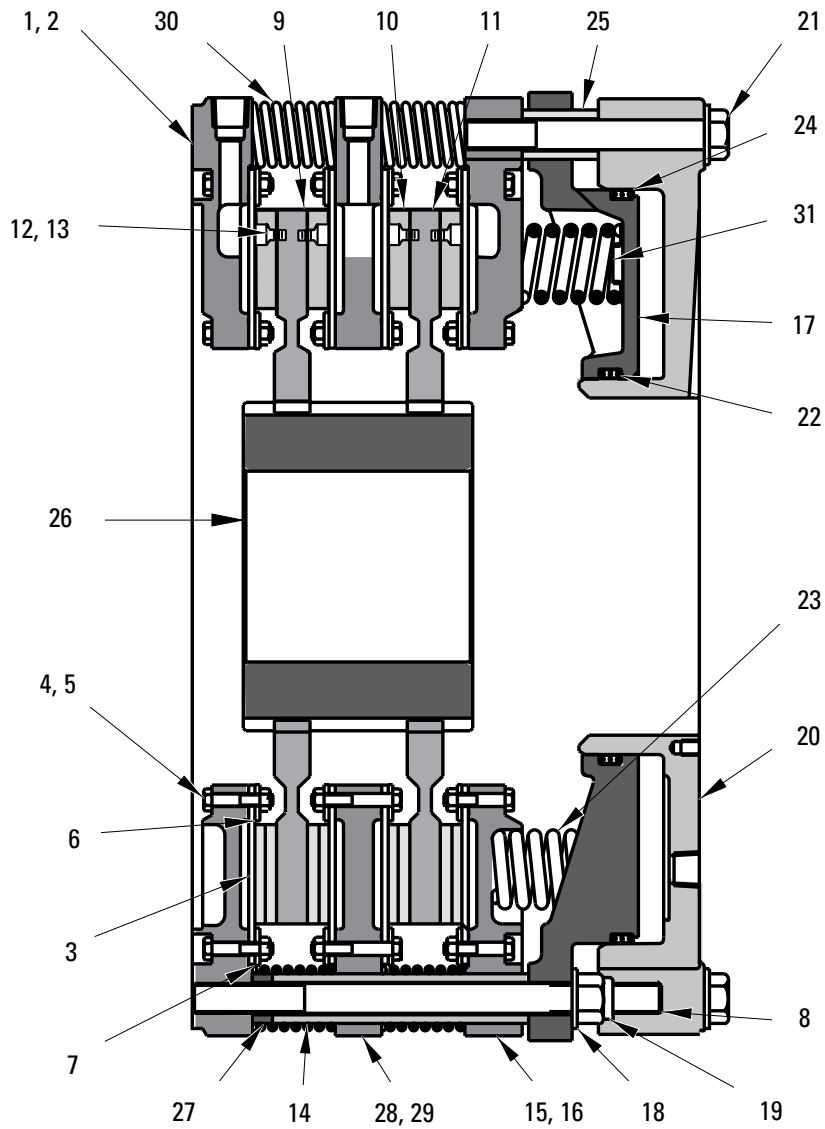

Item	Description
1	Mounting Flange Sub-Assembly
2	Mounting Flange
3	Wear Plate
4	Hex Head Screw
5	Locknut
6	Inner Support Ring
7	Outer Support Ring
8	Stud
9	Friction Disc Sub-Assembly
10	Friction Disc
11	Friction Disc Core
12	Flat Head Screw
14	Clamp Tube
15	Pressure Plate Sub-Assembly
16	Pressure Plate

Item	Description
17	Spring Housing
18	Flat Washer
19	Locknut
20	Cylinder
21	Hex Head Screw
22	Inner Seal
23	Spring
24	Outer Seal
25	Spacer Tube
26	Gear
27	Wear Spacer
28	Reaction Plate Sub-Assembly
29	Reaction Plate
30	Release Spring
31	Spring Retainer

Airflex® WCS Elements

Form WC 1104 — Dimensional Data

Section D

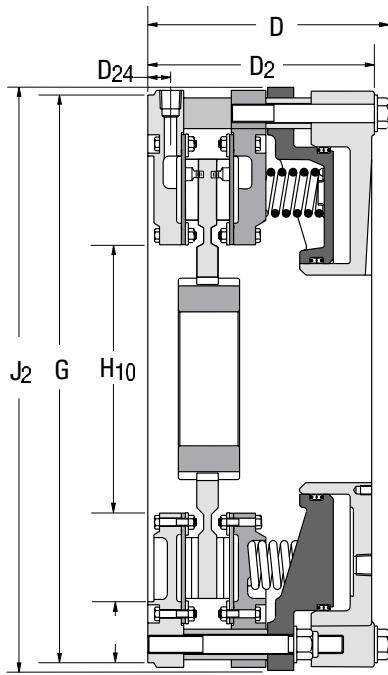

Single Disc

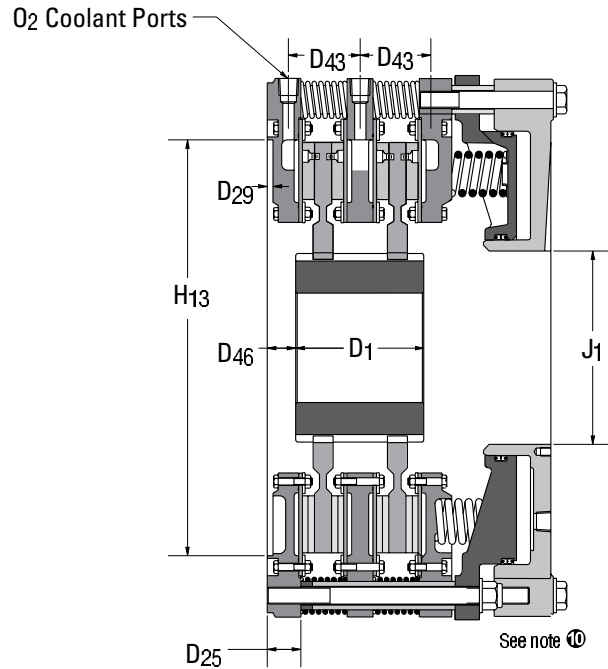

Dual Disc

* Size 18, 24 & 36
Customer's mounting plate must provide rigid support and contact for this length

Mounting Bolt Circles ²

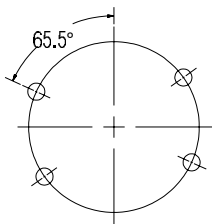

Coolant Inlet Port
8WCS

(4) 0.531 (13,5)Ø Mounting Holes Based on 6 equally spaced as shown on 11.125

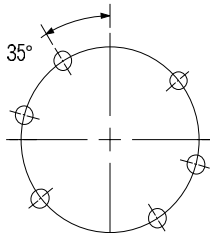

Coolant Inlet Port
14WCS

(6) 0.656 (16,7)Ø Mounting Holes Based on 8 equally spaced as shown on 17.500

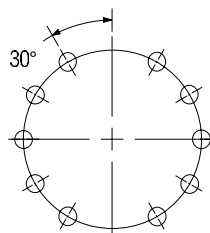

Coolant Inlet Port
18WCS

(10) 0.656 (16,75)Ø Mounting Holes Based on 12 equally spaced as shown on 22.000

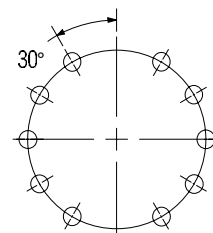

Coolant Inlet Port
24WCS

(10) 0.656 (16,75)Ø Mounting Holes Based on 12 equally spaced as shown on 22.000

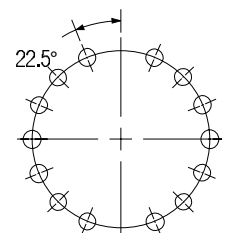

Coolant Inlet Port
36WCS

(14) 1.062 (27,0)Ø Mounting Holes Based on 16 equally spaced as shown on 42.000

English	Dimensions in inches														
Size	D ₂₄	D ₂₅	D ₂₉	D ₄₆	D ₄₃	G [⊕]	H ₁₀	H ₁₃ [⊕]	J ₁	J ₂ [⊕]	H ₄	O ₂ [⊕]			
												No.	Size [⊕]	Bolt Circle Size	Bolt Circle
8WCS _e	0.81	1.25	0.250		2.56	12.125	4.12	8.375	3.12	12.24	3	1/4-20NC-2	3.500	3/8-18	6.63
14WCS _e	0.91	1.41	0.250	⊕	2.81	18.750	7.12	14.375	6.00	18.94	3	3/8-16NC-2	6.500	1/2-14	11.50
18WCS _e	0.93	1.47	0.250	1.25	3.14	23.250	11.00	18.250	8.50	23.69	3	3/8-16NC-2	9.125	1/2-14	15.25
24WCS _e	1.06	1.75	0.250	1.38	4.13	29.998	12.75	24.375	11.50	30.89	4	3/8-16NC-2	12.250	1/2-14	18.50
36WCS _e	1.52	2.58	0.280	2.38	4.88	44.498	16.50	18.375	16.50	45.01	4	1/2-13NC-2	17.500	3/4-14	28.00

SI	Dimensions in millimeters														
Size	D ₂₄	D ₂₅	D ₂₉	D ₄₆	D ₄₃	G [⊕]	H ₁₀	H ₁₃ [⊕]	J ₁	J ₂ [⊕]	H ₄	No.	Size [⊕]	Bolt Circle Size	Bolt Circle
8WCS _e	21	32	6,4		65	308,0	105	212,7	79	311	3	1/4-20NC-2	88,9	3/8-18	168
14WCS _e	23	36	6,4	⊕	71	476,3	181	365,1	152	481	3	3/8-16NC-2	165,1	1/2-14	292
18WCS _e	24	37	6,4	32	80	590,6	279	463,5	216	602	3	3/8-16NC-2	231,8	1/2-14	387
24WCS _e	27	44	6,4	35	105	761,9	324	619,1	292	785	4	3/8-16NC-2	311,2	1/2-14	470
36WCS _e	39	65	7,1	60	124	1130,2	419	466,7	419	1143	4	1/2-13NC-2	444,5	3/4-14	711

Airflex® WCS Elements

Form WC 1103 Dimensional Data

Section D

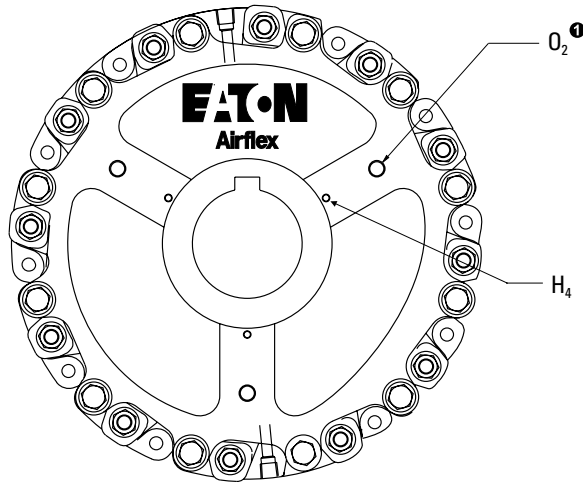

English	Dimensions in inches						
108WCS	1.38	2.50	7.18	1.75	6.68	4	3/8-18 NPT
208WCS	1.63	2.50	9.78	4.00	9.25	6	3/8-18 NPT
308WCS	1.88	2.31	12.34	7.75	11.81	8	3/8-18 NPT
114WCS	2.13	4.38	8.51	2.88	7.72	4	1/2-14 NPT
214WCS	2.63	4.49	11.41	4.38	10.70	6	1/2-14 NPT
118WCS	2.75	5.75	9.98	2.50	9.29	4	1/2-14 NPT
218WCS	3.38	5.88	13.33	5.63	12.55	6	1/2-14 NPT
318WCS	4.13	5.81	16.57	9.62	15.82	8	1/2-14 NPT
418WCS	4.63	5.81	19.89	12.50	19.02	10	1/2-14 NPT
124WCS	3.50	7.50	12.02	3.50	11.04	4	3/4 SAE ORB
224WCS	4.75	7.50	16.07	8.63	15.05	6	3/4 SAE ORB
324WCS	5.50	7.38	20.12	13.19	19.00	8	3/4 SAE ORB
424WCS	6.00	7.38	24.08	16.44	23.80	10	3/4 SAE ORB
136WCS	5.63	10.63	15.38	5.00	14.28	4	1 1/4 SAE ORB
236WCS	7.62	10.75	20.39	9.00	19.14	6	1 1/4 SAE ORB
336WCS	7.25	10.88	25.33	13.00	24.02	8	1 1/4 SAE ORB
436WCS	8.00	10.88	30.30	18.00	28.89	10	1 1/4 SAE ORB

Size	Bore Range ③		D	D ₁	D ₂	O Coolant Ports ⑥	
	Min.	Max.				No.	Size
108WCS	35	64	182	44	170	4	3/8-18 NPT
208WCS	41	64	248	102	235	6	3/8-18 NPT
308WCS	48	59	313	197	300	8	3/8-18 NPT
114WCS	54	111	216	73	272	4	1/2-14 NPT
214WCS	67	114	290	111	267	6	1/2-14 NPT
118WCS	70	146	253	64	236	4	1/2-14 NPT
218WCS	86	149	339	143	319	6	1/2-14 NPT
318WCS	105	148	421	222	402	8	1/2-14 NPT
418WCS	118	148	505	244	483	10	1/2-14 NPT
124WCS	89	191	305	310	282	4	3/4 SAE ORB
224WCS	121	191	408	219	382	6	3/4 SAE ORB
324WCS	140	187	511	335	483	8	3/4 SAE ORB
424WCS	152	187	518	430	605	10	3/4 SAE ORB
136WCS	143	270	391	127	363	4	1 1/4 SAE ORB
236WCS	194	273	518	229	486	6	1 1/4 SAE ORB
336WCS	184	276	643	330	610	8	1 1/4 SAE ORB
436WCS	203	276	770	457	734	10	1 1/4 SAE ORB

SI	Dimensions in millimeters					
----	---------------------------	--	--	--	--	--

Notes:

- ① Only two ports, 180° apart, furnished on sizes 8 and 14WCS.
- ② To insure proper cooling, inlet port must be located at the six o'clock position.
- ③ Tolerance Sizes 8WCS thru 24 WCS +0.000/0.003 (+0.00/-0.08) 36WCS +0.000/-0.005 (+0.00/-0.13)
- ④ Tolerance +0.003/-0.000 in (+0.00/-0.00 mm)
- ⑤ American National Pipe Thread.
- ⑥ 1.00 in (25mm) for 108WCS. 1.38 in (35mm) for 208WCS. 0.19 in (4.8mm) for 308WCS.
- ⑦ 1.06 in (27mm) for 114WCS and 314WCS. 1.69 in (43mm) for 214WCS.
- ⑧ Maximum bore sizes are based on flat keys, allow able gear hub stresses and torque ratings with a full complement of springs.
- ⑨ Maximum diameter of "as cast" surfaces.
- ⑩ Some high torque applications of three and four disc elements require additional torsional support on the cylinder end of the unit. Contact your local Airflex representative for more details.

Airflex® WCS Technical Data

Section D

English			lb in	psi	HP	GPM	lbft ²		
108WCS	146244	415313	5600	80	30	3	6.7E-02	9	0.8
208WCS	146245	415314	10000	80	60	6	1.7E-02	12	1.5
308WCS	146376	416457	13950	80	90	9	7.4 E-03	15	2.33
114WCS	146229	415454	20000	80	60	6	2.4E-02	64	6.4
214WCS	146230	415302	37500	80	120	12	6.0E-03	83	12.6
118WCS	146309	302813	40000	80	120	12	1.3E-02	170	20
218WCS	146318	302907	76000	80	240	24	3.2E-03	220	40
318WCS	146311	413208	112000	80	360	36	1.4 E-03	270	60
418WCS	146312	414111	148000	80	480	48	8.0 E-04	320	80
124WCS	146314	411673	82000	80	270	27	8.1E-03	622	78
224WCS	146340	410970	157000	80	540	54	2.0E-03	822	158
324WCS	146371	412433	232000	80	810	81	8.9 E-04	1022	238
424WCS	146372	413195	307000	80	1080	108	5.0 E-04	1222	318
136WCS	146347	415871	283000	80	650	65	2.9E-03	4922	324
236WCS	146341	416069	532000	80	1300	130	7.2E-04	6323	667
336WCS	146272	416539	781000	80	1950	195	3.2 E-04	7724	1010
436WCS	146369	416537	1030000	80	2600	260	1.8 E-04	9125	1353

Size	Ø Part Number	Gear Part Number	Ⓜ Torque Rating	Release Pressure	Ⓜ Thermal Rating	Ⓜ Water Flow Rate	C Pressure Drop Coefficient	Housing	Disc & Gear
Wk²									
J									
108WCS	146244	415313	632	5,5	22,4	11,4	3,2 E-04	0,38	0,03
208WCS	146245	415314	1129	5,5	44,7	22,7	8,2 E-05	0,51	0,06
308WCS	146376	416457	1576	5,5	67	34,1	3,5 E-03	0,64	
114WCS	146229	415454	2258	5,5	44,7	22,7	1,2 E-04	2,70	0,27
214WCS	146230	415302	4234	5,5	89,5	45,4	2,9 E-05	3,50	0,53
118WCS	146309	302813	4516	5,5	89,5	45,4	6,3 E-05	7,16	0,84
218WCS	146318	302907	8580	5,5	179,0	90,9	1,5 E-05	9,27	1,69
318WCS	146311	413208	12645	5,5	268,5	136,3	6,7 E-06	11,38	2,53
418WCS	146312	414111	16709	5,5	357,9	181,7	3,9 E-06	13,48	3,37
124WCS	146314	411673	9258	5,5	201,3	102,2	3,9 E-05	26,21	3,29
224WCS	146340	410970	17725	5,5	402,7	204,4	9,6 E-06	34,64	6,66
324WCS	146371	412433	26193	5,5	604,0	306,6	4,3 E-06	43,07	10,03
424WCS	146372	413195	34660	5,5	805,4	408,9	2,4 E-06	51,50	13,40
136WCS	146347	415871	31951	5,5	484,7	246,1	1,4 E-05	207,41	13,65
236WCS	146341	416069	60063	5,5	969,4	492,1	3,5 E-06	266,45	28,11
336WCS	146272	416539	88175	5,5	1454,1	738,2	1,5 E-06	325,49	42,56
436WCS	146369	416537	116287	5,5	1938,8	984,3	8,7 E-07	384,53	57,02

SI		Nm	bar	kW	dm ³ /min	kgm ²			
----	--	----	-----	----	----------------------	------------------	--	--	--

Notes:

- ① Basic part number only. Gear must be ordered separately.
- ② Torque ratings are for new linings. Torque decreases with lining wear. At the worn out condition, torque is approximate 0.66 of values shown. Minimum releasing pressure 80 psi (5,5 bar).
- ③ Based upon a 70°F (21°C) fresh water inlet temperature and a 50°F (28°C) temperature rise between inlet and outlet. See cooling requirements.

- ④ To insure proper cooling, inlet port must be located at the six o'clock position. Maximum allowable inlet pressure is 45 psi (3,1 bar).
- ⑤ Based upon a continuous slip velocity of 4500 fpm (22,9 mps).
- ⑥ Maximum freewheeling velocity is 7500 fpm (38,1 mps)
- ⑦ Located from mounting flange surface.
- ⑧ Absolute volume of releasing cylinder.
- ⑨ Contact factory for dimensions.

Airflex® WCS Technical Data

Section D

English	rpm		lb		in		in ₃		
108WCS	2150	3400	90	15	3.4	2.0	30	12	10
208WCS	2150	3400	116	30	4.7	3.4	30	24	20
308WCS	2150	3400	121	59	⑤	⑤	30	36	30
114WCS	1260	2100	222	48	4.1	2.4	75	40	29
214WCS	1260	2100	287	86	5.6	3.7	75	75	58
118WCS	955	1600	418	87	4.0	2.6	133	65	54
218WCS	955	1600	548	180	5.5	4.2	133	125	108
318WCS	955	1600	413	273	7.4	6.2	133	185	162
418WCS	955	1600	458	366	10	7.6	133	245	216
124WCS	715	1200	458	180	5.2	3.3	259	160	126
224WCS	715	1200	665	395	7.6	5.7	259	320	252
324WCS	715	1200	872	610	10	8	259	480	378
424WCS	715	1200	1079	625	12.4	10.1	259	640	504
136WCS	475	700	2302	363	6.9	4.3	612	600	337
236WCS	475	700	3300	805	9.5	6.8	612	1135	673
336WCS	475	700	4298	1247	12.11	9.2	612	1670	1009
436WCS	475	700	5296	1689	14.67	11.8	612	2205	1345
Size	Maximum Slip Speed ⑥	Maximum Freewheeling Speed ⑥	Housing	Disc & Gear	Housing	Disc & Gear	⑦ Releasing Volume New	Water Volume	Lining Wear Volume
			Weight Mass		Center of Gravity ⑧				
108WCS	2150	3400	41	7	86	51	0,5	0,20	0,16
208WCS	2150	3400	53	14	119	86	0,5	0,39	0,33
308WCS	2150	3400	55	27	⑨	⑨	0,5	0,60	0,48
114WCS	1260	2100	101	22	104	61	1,2	0,66	0,48
214WCS	1260	2100	130	39	142	94	1,2	1,23	0,95
118WCS	955	1600	146	39	102	66	2,2	1,07	0,89
218WCS	955	1600	167	82	140	107	2,2	2,05	1,77
318WCS	955	1600	187	124	188	157	2,2	3,04	2,66
418WCS	955	1600	208	166	254	193	2,2	4,02	3,55
124WCS	715	1200	208	82	132	84	4,3	2,63	2,07
224WCS	715	1190	302	179	193	145	4,3	5,26	4,14
324WCS	715	1190	395	277	254	203	4,3	7,89	6,21
424WCS	715	1190	489	374	315	257	4,3	10,51	8,28
136WCS	475	700	1044	165	175	109	10,1	9,86	5,54
236WCS	475	700	1497	365	241	173	10,1	18,65	11,06
336WCS	475	700	1949	566	308	234	10,1	27,44	16,58
436WCS	475	700	2402	766	373	300	10,1	36,22	22,10
SI	rpm		kg		mm		dm ₃		

WCSB Description

Section D

The WCSB is a disc-type, water-cooled and air-cooled unit. These units provide dynamic tensioning, static holding and emergency stopping removing the need for multiple braking systems.

The WCSB incorporates water-cooled and air-cooled friction discs within one brake that is pressure-applied and spring-applied. The pressure-applied side is used for dynamic tensioning. The spring-applied side is used for emergency stopping and holding.

Pressurizing the air-applied side causes the piston to clamp the water-cooled friction discs between the water-jackets. Immediately following pressurization of the air-applied side, air pressure must be applied to release the spring-applied side. Applying air to the spring-applied side pushes the spring-applied cylinder back and releases the air-cooled friction disc. This will ensure that the load does not free-fall.

Once the spring-applied side is fully released, air pressure is slowly released from the large and small pistons on the air-applied side until the load begins to move. Releasing air-pressure from the spring-applied side causes the cylinder to move forward, clamping down on both the air-cooled and water-cooled friction discs during an emergency stop or for static holding.

The air-applied piston incorporates a small and large piston. The small piston can be used to provide an air pressure that can be managed by standard regulators which increases controllability during the tensioning mode with light loads.

Element sizes are indicated by the number of water-cooled friction discs, the number of air-cooled friction discs and the disc diameter in inches. For instance, the 324WCSB 2W/1A has 3 friction discs. Two of the friction discs are water-cooled and one of the friction discs is air-cooled. The diameter of the water-cooled friction discs is 24 inches.



Features:

Combination Power Packs

Dynamic tensioning, static holding and emergency stopping are provided by one brake removing the need for multiple braking systems.

Dual Air-Applied Pistons

Dual air-applied pistons provide greater controllability with a varying range of loads.

Torque and Horsepower Independent of Rotational Speed

Torque can be obtained at all speeds and the WCSB can withstand high thermal power loading throughout the tensioning cycle.

Unique Friction Couple

A specially formulated friction material, interfacing with a copper alloy surface, eliminates the stick-slip characteristics associated with ordinary frictional devices.

Optional Corrosion Resistance Package

For marine environments, protective coatings are available to minimize corrosion.

Where used:

- Drawworks
- Mooring Systems
- Log Yarders

WCSB Component Parts

Section D

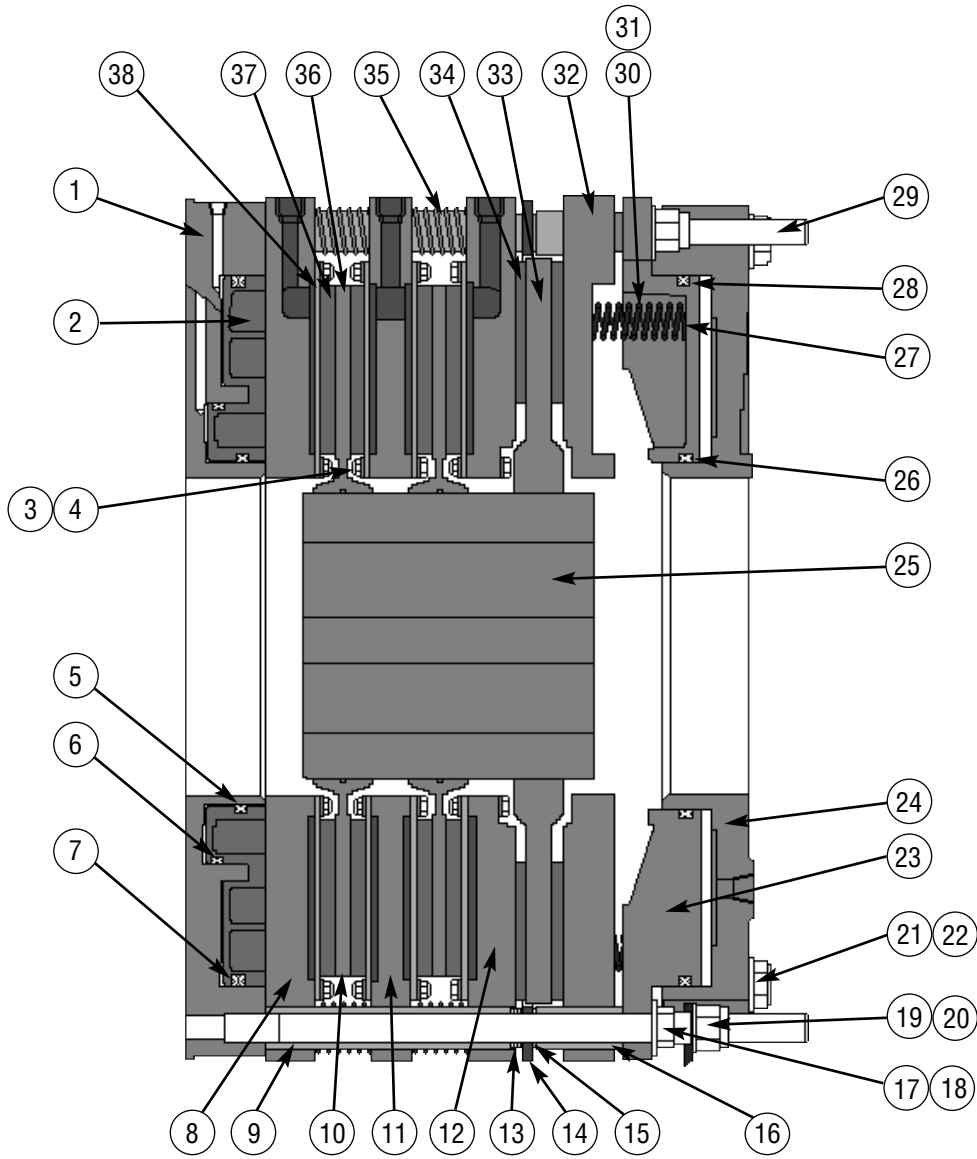

Item	Description
1	Mounting Flange/Cylinder
2	Air-Applied Piston
3	Hex Head Screw
4	Locknut
5	Air-Applied Inner Seal
6	Air-Applied Intermediate Seal
7	Air-Applied Outer Seal
8	Water-Cooled Pressure Plate
9	Clamp Tube
10	Water-Cooled Friction Disc Assembly
11	Reaction Plate
12	End Plate
13	Wear Spacers
14	Stop Plate
15	Wear Spacer
16	Clamp Tube
17	Sleeve Nut
18	Flat Washer
19	Self Locking Nut

Item	Description
20	Flat Washer
21	Hex Head Screw
22	Flat Washer
23	Spring Housing
24	Cylinder
25	Gear
26	Spring-Applied Inner Seal
27	Spring Retainer
28	Spring-Applied Outer Seal
29	Stud
30	Inner Spring
31	Outer Spring
32	Spring-Applied Pressure Plate
33	Air-Cooled Solid Disc
34	Air-Cooled Friction Disc
35	Release Spring
36	Water-Cooled Friction Disc Core
37	Water-Cooled Friction Disc
38	Wear Plate

Note:

- ❶ The above cross-section shows a unit with two water-cooled friction disc assemblies. For units with one water-cooled friction disc assembly, item 11 is not required.

WCSB Elements - Dimensional Data*

Section D

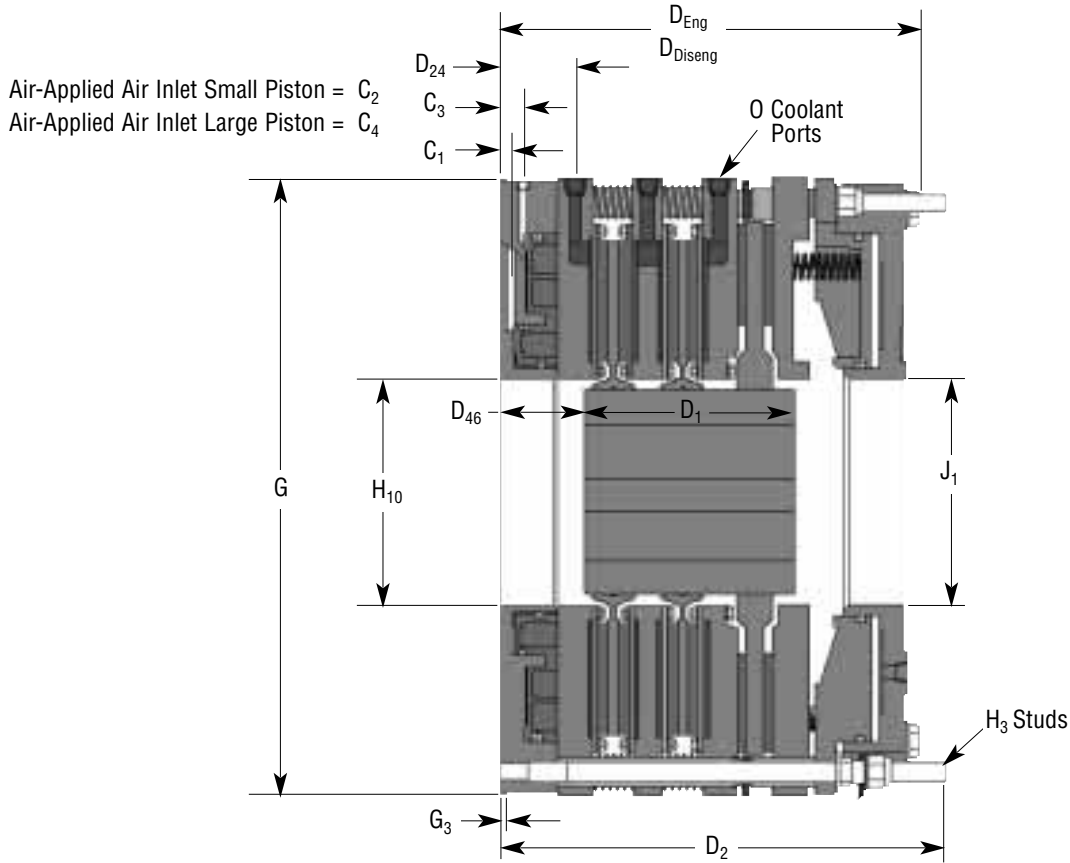

Mounting Bolt Circles ①

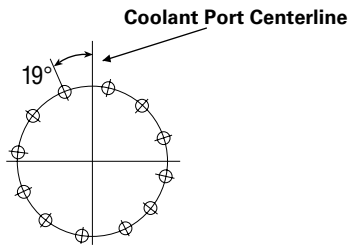

Pressure Plate Coolant Inlet Port
24WCSB
 12-0.656 (16,7) Dia. Holes Equally Spaced Holes on a 28.750" (730,3) BC

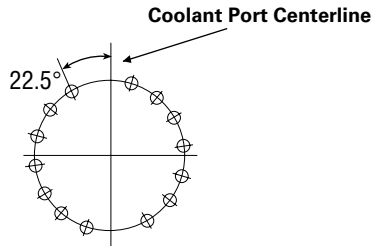

Pressure Plate Coolant Inlet Port
36WCSB
 14-1.062 (27,0) Dia. Holes based on 16 Equally Spaced Holes on a 42.000" (1066,8) BC

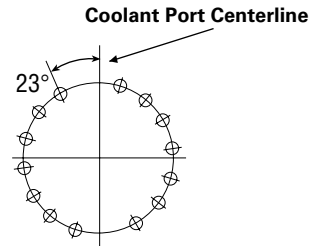

Pressure Plate Coolant Inlet Port
48WCSB
 14-1.438 (36,5) Dia. Holes based on 16 Equally Spaced Holes on a 54.000" (1371,6) BC

* Data shown is subject to change. Please consult factory for current dimensional data.

English	Dimensions in inches														
24WCSB	.87	1/4-18	1.28	1/2-14	4.00	3.63	29.998	.125	11.38	11.50	12	1 1/8 - 7	27.875	1/2-14 NPT	18.500
36WCSB	.99	3/8-18	1.50	3/4-14	5.31	6.00	44.498	.250	16.50	16.50	16	1 3/8 - 6	41.500	3/4-14 NPT	28.000
48WCSB	1.17	1/2-14	1.80	1-11 1/2	5.94	6.75	56.499	.250	23.00	23.00	16	1 3/8 - 6	53.688	1-11 1/2 NPT	41.500

Size	C_1	C_2	C_3	C_4	D_{24}	① D_{46}	② G	G_3	H_{10}	J_1	No.	Size	Bolt Circle	Size	Bolt Circle
											No.	Size	Bolt Circle	Size	Bolt Circle
24WCSB	22,1	1/4-18	32,5	1/2-14	101,6	92,2	761,9	3,2	289,1	292,1	12	1 1/8-7	708,0	1/2-14 NPT	469,9
36WCSB	25,1	3/8-18	38,1	3/4-14	134,9	152,4	1130,1	6,4	419,1	419,1	16	1 3/8-6	1054,1	3/4-14 NPT	711,2
48WCSB	29,7	1/2-14	45,7	1-11 1/2	150,9	171,5	1435,1	6,4	584,2	584,2	16	1 3/8-6	1363,7	1-11 1/2 NPT	1054,1

SI Dimensions in millimeters

WCSB Elements

Dimensional Data*

Section D

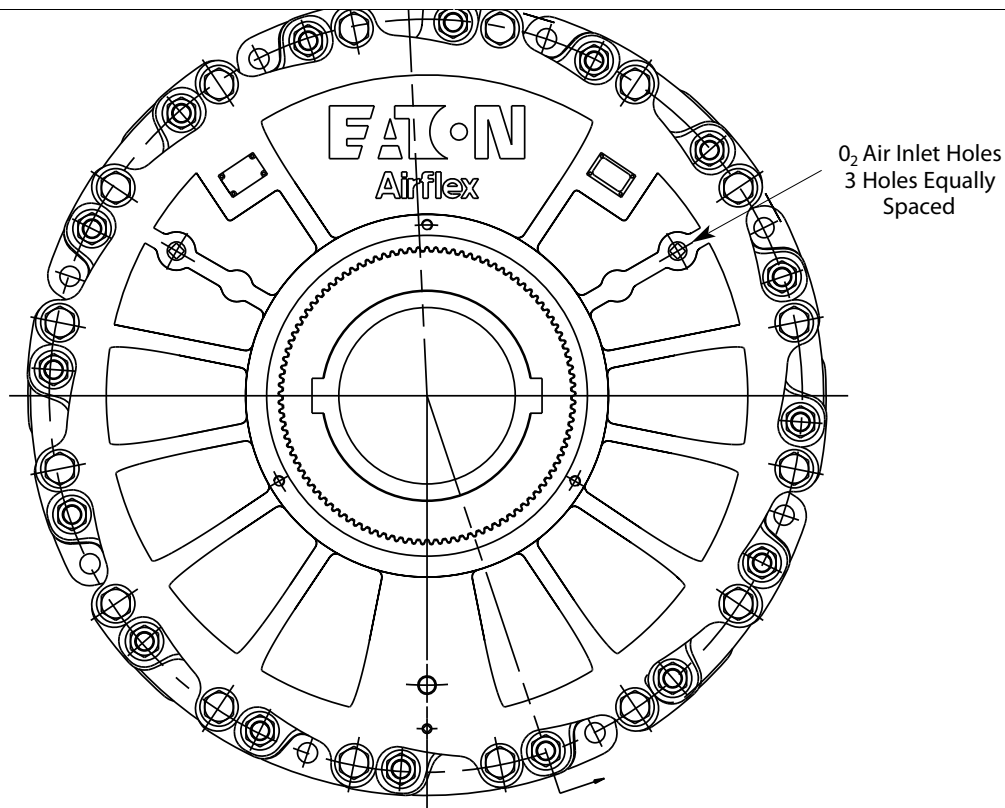

English		Dimensions in inches						
224WCSB 1W/1A	8.63	17.44	18.59	18.77	4	3/4 SAE ORB	6.125	8.250
324WCSB 2W/1A	13.19	21.94	22.45	22.72	8	3/4 SAE ORB	7.000	8.250
424WCSB 3W/1A	16.94	28.19	26.50	26.86	12	3/4 SAE ORB	7.750	8.000
236WCSB 1W/1A	10.00	22.81	24.69	25.01	4	1 1/4 SAE ORB	8.875	11.500
336WCSB 2W/1A	14.00	28.81	29.54	29.87	8	1 1/4 SAE ORB	10.250	11.250
436WCSB 3W/1A	19.50	36.31	34.40	34.81	12	1 1/4 SAE ORB	11.250	11.375
248WCSB 1W/1A	11.25	27.46	30.55	30.86	4	1 1/4 SAE ORB	11.375	16.250
348WCSB 2W/1A	16.75	34.21	36.05	36.51	8	1 1/4 SAE ORB	13.000	16.250
448WCSB 3W/1A	22.50	41.46	41.54	42.16	12	1 1/4 SAE ORB	14.375	16.250
Size	D ₁	D ₂	D _{Eng}	D _{Diseng}	No.	Size	Min.	Max.
					O Coolant Ports ⑤		Bore Range	
					No.	Size	Min.	Max.
224WCSB 1W/1A	219,2	443,0	472,2	476,8	4	3/4 SAE ORB	155,6	209,6
324WCSB 2W/1A	335,0	557,0	570,2	577,1	8	3/4 SAE ORB	77,8	209,6
424WCSB 3W/1A	430,3	716,0	673,1	682,2	12	3/4 SAE ORB	196,9	203,2
236WCSB 1W/1A	254,0	579,4	627,1	635,3	4	1 1/4 SAE ORB	225,4	292,1
336WCSB 2W/1A	355,6	731,8	750,3	758,7	8	1 1/4 SAE ORB	260,4	285,8
436WCSB 3W/1A	495,3	922,3	873,8	884,2	12	1 1/4 SAE ORB	285,8	288,9
248WCSB 1W/1A	285,8	697,5	776,0	783,8	4	1 1/4 SAE ORB	288,9	412,8
348WCSB 2W/1A	425,5	868,9	915,7	927,4	8	1 1/4 SAE ORB	330,2	412,8
448WCSB 3W/1A	571,5	1053,1	1055,1	1070,9	12	1 1/4 SAE ORB	365,1	412,8
SI	Dimensions in millimeters							

Note:

- ① To insure proper cooling, inlet port must be located at the six o'clock position.
- ② Tolerance for the 24WCSB is +0.000/-0.003 (+0,000/-0,08). Tolerance for the 36WCSB and the 48WCSB is +0.000/-0.005 (+0,000/-0,13).
- ③ American National Standard for Unified Screw Threads.
- ④ American National Pipe Thread.
- ⑤ Water-cooled pressure plate and end plate have single inlet and outlet cooling ports. Reaction plates have dual inlet and outlet cooling ports
- ⑥ Tolerance +/-0.030 (+/-0,76).

* Data shown is subject to change. Please consult factory for current dimensional data.

WCSB Elements

Technical Data*

Section D

English			lb-in. @ 80 psi			lb-in	lb-in. @ 120 psi		HP
224WCSB 1W/1A	146452C	410970	43470	117530	161000	351000	378000	392000	270
324WCSB 2W/1A	146453C	412433	86940	235060	322000	523000	505000	620000	540
424WCSB 3W/1A	146454C	413195	130680	353320	484000	676000	617000	844000	810
236WCSB 1W/1A	146436C	416821	111120	351880	463000	1086000	1330000	1218000	650
336WCSB 2W/1A	146477C	416842	222240	703760	926000	1558000	1747000	1872000	1300
436WCSB 3W/1A	146402C	416676	333360	1055640	1389000	1969000	2107000	2514000	1950
248WCSB 1W/1A	146478C	416795	245180	697820	943000	2526000	2518000	2907000	1300
348WCSB 2W/1A	146400C	416688	490360	1395640	1886000	3335000	3372000	4239000	2600
448WCSB 3W/1A	146479C	416797	735800	2094200	2830000	3976000	4052000	5548000	3900
Size	① Part Number	Gear Part Number	Small Piston	Large Piston	Both Pistons	② Spring Applied Dynamic Torque	② Spring Applied Static Torque	⑤ Maximum Dynamic Torque	④ Thermal Rating
			Air-Applied Dynamic Torque ③						
			Small Piston	Large Piston	Both Pistons				
224WCSB 1W/1A	146452C	410970	4908	13269	18177	39628	42676	44257	201,3
324WCSB 2W/1A	146453C	412433	9816	26538	36354	59047	57015	69998	402,7
424WCSB 3W/1A	146454C	413195	14754	39890	54644	76320	69659	95288	604,0
236WCSB 1W/1A	146436C	416821	12545	39727	52273	122609	150157	137512	484,7
336WCSB 2W/1A	146477C	416842	25091	79455	104545	175898	197236	211349	969,4
436WCSB 3W/1A	146402C	416676	37636	119182	156818	222300	237880	283831	1454,1
248WCSB 1W/1A	146478C	416795	27681	78784	106465	285185	284282	328200	969,4
348WCSB 2W/1A	146400C	416688	55362	157568	212929	376522	380699	478583	1938,8
448WCSB 3W/1A	146479C	416797	83072	236435	319507	448890	457471	626369	2908,2
SI			Nm @ 5,5 bar			Nm	Nm @ 10,3 bar		kW

Notes:

- ① Basic part number only. Gear must be ordered separately.
- ② Torque is based on a spring set release pressure of 120 psi and the maximum amount of apply springs. To decrease release pressure, springs can be removed. The maximum number of springs for each size are as follows: 24WCSB – 48 (24 outer springs and 24 inner springs), 36WCSB – 128 (64 outer springs and 64 inner springs), 48WCSB – 112 springs.
- ③ Exact torque rating is dependent upon applied pressure. Maximum allowable air-applied pressure is 150 psi
- ④ Based upon a 70° F (21° C) fresh water inlet temperature and a 50° F (28° C) temperature rise between inlet and outlet. See cooling requirements.
- ⑤ Maximum torque results when 120 psi is applied to the air-applied side and the spring-applied side is fully set simultaneously. If air pressure is lost, the torque will drop to the spring-applied static torque.

WCSB Elements

Technical Data

Section D

English	PSI			GPM			in ³			rpm			in ³	
224WCSB 1W/1A	17	6	5	27	4.30E-03	1.20E-01	160	136	715	1200	73	159		
324WCSB 2W/1A	18	7	6	54	1.10E-03	6.10E-02	320	272	715	1200	104	190		
424WCSB 3W/1A	19	8	7	81	4.80E-04	4.10E-02	480	408	715	1200	135	221		
236WCSBEP 1W/1A	18	6	5	78	1.20E-03	8.90E-02	600	308	475	700	220	424		
336WCSBEP 2W/1A	19	7	6	156	2.80E-04	5.80E-02	1135	616	475	700	318	522		
436WCSBEP 3W/1A	20	8	7	234	1.20E-04	3.90E-02	1670	924	475	700	416	620		
248WCSB 1W/1A	17	6	5	130	1.10E-03	4.60E-02	700	546	360	600	467	821		
348WCSB 2W/1A	18	7	6	260	2.30E-04	3.60E-02	1400	1091	360	600	679	1033		
448WCSB 3W/1A	19	8	7	390	1.00E-04	2.40E-02	2100	1637	360	600	891	1245		

Size	Small Large Both Parasitic Pressure			Water Flow [®]	C ₁ Pressure Drop [®] Coefficient		Water Volume	WC Lining Wear Volume	Maximum [®] Slip Speed	Maximum [®] Freewheeling Speed	New Air Applied Engaging Volume New	Worn [®] Volume Worn [®]
	Small	Large	Both		C ₁	C ₂						
224WCSB 1W/1A	1,17	0,41	0,34	102,2	2,1E-05	2,2E-03	2,6	2,2	715	1200	1,2	2,6
324WCSB 2W/1A	1,24	0,48	0,41	204,4	5,2E-06	1,1E-03	5,3	4,5	715	1200	1,7	3,1
424WCSB 3W/1A	1,31	0,55	0,48	307,0	2,3E-06	7,4E-04	7,9	6,7	715	1200	2,2	3,6
236WCSBEP 1W/1A	1,24	0,41	0,34	295,3	5,7E-06	1,6E-03	9,8	5,0	475	700	3,6	6,9
336WCSBEP 2W/1A	1,31	0,48	0,41	590,5	1,3E-06	1,1E-03	18,6	10,1	475	700	5,2	8,6
436WCSBEP 3W/1A	1,38	0,55	0,48	885,8	5,9E-07	7,1E-04	27,4	15,1	475	700	6,8	10,2
248WCSB 1W/1A	1,17	0,41	0,34	492,1	5,2E-06	8,4E-04	11,5	8,9	360	600	7,7	13,5
348WCSB 2W/1A	1,24	0,48	0,41	984,2	1,1E-06	6,5E-04	22,9	17,9	360	600	11,1	16,9
448WCSB 3W/1A	1,31	0,55	0,48	1476,3	4,8E-07	4,4E-04	34,4	26,8	360	600	14,6	20,4

SI	bar			dm ³ /min			dm ³			rpm			dm ³	
----	-----	--	--	----------------------	--	--	-----------------	--	--	-----	--	--	-----------------	--

English	in ³		lb-ft ²		lb		in	
224WCSB 1W/1A	259	140	1260	363	8.71	7.90		
324WCSB 2W/1A	259	216	1448	561	10.81	9.98		
424WCSB 3W/1A	259	291	1641	745	12.96	11.89		
236WCSBEP 1W/1A	612	919	4466	873	12.54	11.34		
336WCSBEP 2W/1A	612	1284	5026	1227	14.92	13.76		
436WCSBEP 3W/1A	612	1659	5954	1615	17.78	16.33		
248WCSB 1W/1A	1115	3128	7869	1689	15.15	12.60		
348WCSB 2W/1A	1115	4603	9189	2480	18.03	15.33		
448WCSB 3W/1A	1115	6086	10521	3283	20.89	18.11		

Size	Spring-Applied Release Volume	Wk ² Disc & Gear J	Weight Housing Mass		Center of Gravity [®] Housing Disc & Gear Center of Gravity	
			Disc & Gear	Disc & Gear	Housing	Disc & Gear
224WCSB 1W/1A	4,2	5,9	572	165	221,2	200,7
324WCSB 2W/1A	4,2	9,1	657	254	274,6	253,5
424WCSB 3W/1A	4,2	12,3	744	338	329,2	302,0
236WCSBEP 1W/1A	10,0	38,7	2026	396	318,5	288,0
336WCSBEP 2W/1A	10,0	54,1	2280	557	379,0	349,5
436WCSBEP 3W/1A	10,0	69,9	2701	733	451,6	414,8
248WCSB 1W/1A	18,3	131,8	3569	766	384,8	320,0
348WCSB 2W/1A	18,3	194,0	4168	1125	458,0	389,4
448WCSB 3W/1A	18,3	256,5	4772	1489	530,6	460,0

SI	dm ³		kg-m ²		kg		mm	
----	-----------------	--	-------------------	--	----	--	----	--

Notes:

- Absolute volume of cylinder at contact with new and worn friction discs. Worn volume assumes one wear spacer thickness of wear.
 - Coefficients are based on the maximum pressure drop across the individual water cavities of the brake.
 - To insure proper cooling, the inlet port must be at the six o'clock position.
 - Located from the mounting flange surface.
 - Based upon a continuous slip velocity of 4500 fpm (22,9 mps).
 - Maximum freewheeling velocity is 7500 fpm (38,1 mps).
- * Data shown is subject to change. Please consult factory for current dimensional data.

Airflex® Selection Procedure

Section D

General

Technical Section Y of the catalog contains useful information pertaining to the selection, mounting, alignment and control of clutches and brakes in general. Formulas, symbols and units are also identified. It is recommended that Section Y be reviewed before attempting to size a specific product for an application.

WCB elements are used primarily in applications which must slip for long periods of time. Selection criteria are the dynamic slipping torque and the resulting thermal power, neither of which necessitates the use of service factors.

Like all friction material, the torque developed by water-cooled elements is not perfectly constant at a given air pressure. Once per revolution torque variation and drift over time may occur.

Element Torque Adjustment

WCB dynamic torque ratings M_r are based upon an effective pressure p_r of 80 psi (5,5 bar). Maximum allowable operating pressure is 150 psi (10,3 bar). Torque ratings must be adjusted for operating pressure p_o and parasitic loss p_p .

The elements have an inherent parasitic pressure p_p required to cause friction disc engagement which represents the pressure to overcome internal sliding friction and to compress disc releasing springs.

No. of Friction Discs	Pressure p_o	
	psi	bar
1	3	0,21
2	4	0,28
3	5	0,34
4	6	0,41

Element torque M_e is calculated from:

$$M_e = \frac{p_o - p_p}{p_r} \cdot M_r$$

WCS elements are spring-applied, pressure released. Minimum releasing pressure is 80 psi (5,5 bar). Maximum allowable cylinder pressure is 150 psi (10,3 bar). The torque ratings are for new linings. Torque will decrease as lining wears. At the worn out condition, the torque is approximately 0.66 of the new lining condition. Element torque can be regulated by biasing the spring force through control of the minimum releasing pressure and monitoring lining wear.

Thermal Capacity

Thermal capacities are for continuous operation at the coolant flow rate and temperatures indicated. For intermittent duty such as short duration loads or infrequent high inertia stops, the thermal capacities can be increased 50% for periods up to 20 minutes. The coolant flow must be increased accordingly.

Example

What is the dynamic torque capacity of a 224WCB element when used with an operating pressure of 50 psi (3,4 bar)?

$$\begin{aligned} M_e &= \frac{p_o - p_p}{p_r} \cdot M_r \\ &= \frac{50 - 4}{80} \cdot 20000 \\ &= 115000 \text{ lb} \cdot \text{in} \end{aligned}$$

Example

What pressure should be applied to a 118WCB element to develop a torque of 60,000 lb.in (6780 N · m)?

$$\begin{aligned} M_e &= \frac{p_o - p_p}{p_r} \cdot M_r \\ p_o &= \frac{M_e}{M_r} \cdot p_r + p_p \\ &= \frac{60000}{48000} \cdot 80 + 3 \\ &= 103 \text{ psi} \end{aligned}$$

Airflex® Cooling Requirements

Section D

For efficient cooling, an adequate supply of filtered fresh water is required. Excessive water hardness promotes the formation of scale deposits, which in time will affect the service life of the WCB unit. Water of high acidity may cause electrolytic corrosion between the dissimilar metals used in the WCB construction. Water treatment should be considered if the calcium carbonate exceeds 100 ppm. The water pH value should fall between 7.0 and 9.0.

The WCB cooling capacity of 10 HP per gallon per minute (1.97 kW per cubic decimeter per minute) is based on a 50°F (28°C) maximum temperature rise of a fresh water coolant. Maximum outlet water temperature should not exceed 150°F (66°C).

Maximum ambient temperature limit for the WCB is 110°F (43°C). For open loop systems using water, the minimum is 45°F (7°C). Minimum ambient temperature limit for closed loop systems using an ethylene glycol coolant is 0°F (-18°C).

Maximum allowable inlet coolant pressure is 45 psi (3,1 bar). A relief valve should be incorporated in the inlet manifold to prevent pressure surges.

Ethylene glycol is usually added to cooling water (especially in exposed applications) to prevent freezing. An ethylene glycol coolant conforming to SAE Standard J1034 should be used. For preparation of a water/ethylene glycol mix, water which is low in corrosive ions such as chlorides and sulphates should be used. The mixture's pH value should fall between 7.5 and 10.5. The thermal capacity of a mixture is not as great as that of water alone, so coolant flow must be determined from the values given in the table. Because the boiling point of the mixture is higher, a higher outlet coolant temperature is permissible. Ethylene glycol content of the mixture should not exceed 50% by volume. Larger amounts will reduce cooling capacity and can cause coolant leakage, due to overheating.

English Units

30	8.5	165
40	7.7	165
50	6.7	170

Ethylene Glycol Mixture % by Volume	Maximum Outlet Temperature	
	Flow	
	HP/GPM	° F
	kW/dm ³ pM	° C
30	1,67	74
40	1,52	74
50	1,32	77

SI Units

The coolant values are based on balanced parallel coolant flow through each section of the brake. Series flow is not recommended. Inlet and outlet coolant manifolds must be provided with connecting flexible hoses to each brake section. To insure coolant cavities are filled, inlet ports must be at the six o'clock position.

For intermittent duty under certain conditions, such as short duration loads or infrequent high inertia stops, thermal ratings can be exceeded for limited periods.

Pressure drops for parallel balanced flow across the brake can be determined from:

$$p = C_1 (\text{Flow})^2 + C_2 (\text{Flow})$$

where:

p = pressure drop (psi or bar)

C = pressure drop coefficient*

F = flow (gallons/min or dm³/min)

* see WCS technical data section

Example

It is planned to use a 136WCB to handle a thermal load of 300 HP (224 kW). What flow of fresh water is required and what is the pressure drop across the element?

$$\text{GPM} = \frac{P_t}{10 \frac{\text{HP}}{\text{GPM}}}$$

$$= \frac{300}{10}$$

$$= 30$$

$$p = C F^2$$

$$= 2.9 \text{ E } -03 \text{ } 30^2$$

$$= 3 \text{ psi}$$

Airflex® Coolant System

Section D

Liquid to Liquid Coolant System

A typical closed loop liquid to liquid system is shown here. The heat exchanger and its temperature control are replaced by a radiator, fan and motor in a liquid to air system.

